



PowerShield8

Installation Manual

Table of Contents

1 Glossary	4
2 Introduction	5
3 Installation Quick Guide – Lead-Acid install	6
3.1 Samsung Lithium Installation Quick Guide	8
4 The PowerShield8 Battery Monitoring System	9
4.2 Controller	11
4.2.1 LX Controller	11
4.2.2 MX Controller	12
4.2.3 Power Supply Options.....	12
4.2.5 Hub Ports and BBus Communication.....	13
4.2.6 Installation	13
4.3 Hub	14
4.4 mSensor	15
5 Installation	16
5.1 Install Controller and Power-up	16
5.1.1 MX Controller Mounting Using Side Wings	16
5.1.2 MX Controller Rack Mount Instructions.....	17
5.2 Number Blocks	18
5.3 Block Terminal Tags	18
5.4 Mounting Rail for Hubs and mSensors	19
5.5 mSensor Power Leads	19
5.6 Connect mSensors to Blocks.....	21
5.7 Install Hub.....	21
5.8 Connect BBus Cables.....	22
5.9 Install Current Transducer	22
5.10 Connect Ambient Temperature Probe(s)	24
5.11 Confirmation and Configuration	24
6 Thermal Runaway Protection	25
6.1 What is Thermal Runaway?.....	25
6.2 How is Thermal Runaway Prevented?.....	25
6.2.1 Controller Method	25
6.2.2 Hub Method	26
6.2.3 Location of Ambient Temperature Probe	29
Appendix 1 – Controller Panels & Hub Pinouts	30
LX Controller Front Panel	30
LX Controller Rear Panel.....	30
MX Controller Front Panel	32
MX Controller Rear Panel.....	32
Hub Pinout.....	34
Appendix 2 – LED Behaviour	35
PowerShield Controller LEDs	35
mSensor and Hub LEDs	36
Appendix 3 – LX Controller LCD	37
Appendix 4 – Communication Options	38
RS-485	38

Cabling & Termination	38
Appendix 5 – Relays, Auxiliary Inputs and Ambient Temperature.....	39
Relays.....	39
Auxiliary Inputs (LX Controller only)	39
Ambient Temperature (MX Controller only)	39
Appendix 6 – mSensor Power Lead Connection.....	40
Dual mSensor and Blocks with 2 Terminals	40
Single mSensor and Block with 2 Terminals.....	41
Dual mSensor and Blocks with 4 Terminals	42
Single mSensor and Block with 4 Terminals.....	43
mSensor Power Leads with Block Temperature.....	44
mSensor Power Leads without Block Temperature.....	44
Appendix 7 – 4-Wire / Kelvin Connection	45
Resistance.....	45
2-Wire Resistance Measurement	45
4-Wire/Kelvin Resistance Measurement.....	46
Appendix 8 – DC Model Controller Wiring.....	47
DC Model Plug	47
Appendix 9 – Controller Specifications.....	49
LX Controller.....	49
MX Controller.....	50
Appendix 10 – Hub Specifications.....	51
Appendix 11 – mSensor Specifications.....	52
Appendix 12 - PowerShield8 Installation Forms.....	53
6300-107 Facility Information Form (FIF)	53
6300-108 PowerShield8 Controller Information Form (CIF).....	54
6300-109 PowerShield8 String Information Form (SIF).....	55
6300-110 PowerShield8 Block Mapping Form (BMF).....	56

1 Glossary

Cell	The basic electrochemical unit that can receive, store, and deliver electrical energy.
Block	One or more cells in a container also known as a battery. The terms block and jar are interchangeable. For this manual the term has been standardised as block to avoid using the somewhat unwieldy convention of "block/jar" throughout.
String	Two or more blocks connected in series.
Battery Bank	A complete system of parallel connected strings.
PowerShield Controller	Data logger that periodically communicates with <i>PowerShield Hubs</i> and <i>PowerShield mSensors</i> to obtain system measurements. There are two versions of Controller: <ul style="list-style-type: none">• LX Controller: For large installations. Can monitor up to 8 strings and up to 512 blocks.• MX Controller: For small to medium sized installations. Can monitor up to 4 strings and up to 200 blocks.
PowerShield mSensor	A remote sensor that is connected to the blocks. It periodically measures the block voltage, ohmic value and temperature.
PowerShield Hub	A remote sensor that can be used to measure string current and ambient temperature of the battery bank. mSensors can be connected to it so that they share the same communication cable from the <i>PowerShield Controller</i> .
BBus	A daisy chain communication bus used between the <i>PowerShield Controller</i> and <i>PowerShield Hubs</i> or <i>PowerShield mSensors</i> .

2 Introduction

This manual is intended for use with the *PowerShield8* battery monitoring system that uses the *PowerShield8 LX Controller* or *PowerShield8 MX Controller* data logger, *PowerShield mSensor* battery sensors and the *PowerShield Hub*. This manual describes the installation of the system hardware.

For instructions on how to install a *PowerShield8* Controller with a Samsung Lithium system, please refer to section: 3.1 Samsung Lithium Installation Quick Guide

About This Manual

PowerShield8 Installation Manual
Part Number 6300-095 Rev. N
04 March 2026

The information contained in this manual is copyright and is not to be reproduced without the written authority of PowerShield Ltd.

PowerShield Limited
PO Box 102-190
NSMC
North Shore City 0745
New Zealand

PowerShield is committed to being responsible to take care of our environment. PowerShield products and packaging contain materials that are highly recoverable and recyclable. Please consider recycling through proper channels at your local packaging recycler and e-waste recycler.

Safety Information

To ensure that the *PowerShield8* battery monitoring system is installed and used in a safe manner, observe the following guidelines:

- Read this manual completely before installation and follow all safety instructions.
- Installation must be carried out only by suitably trained personnel. Installation must be in an adequately ventilated environment or warranty may be invalidated.
- The *PowerShield8* battery monitoring system operates in a potentially hazardous environment making it imperative that all installation personnel have adequate training and experience. This system is not suitable for use in locations where children are likely to be present.
- Both AC and DC models of *PowerShield Controller* must be installed by a service person and connected to a socket outlet or fixed wiring with a protective earth conductor or connector.
- A readily available disconnect device shall be incorporated in the building wiring or the socket outlet near the *PowerShield Controller* that is readily accessible.
- The power source for the DC model *PowerShield Controller* must be fused with a circuit breaker of no greater than 20A rating. The connection must be installed in a service access area.
- The *PowerShield Controller* contains a coin cell battery. In the interest of safety:
 - replacement of the battery with an incorrect type can defeat a safeguard.
 - disposal of a battery into fire or a hot oven, or mechanically crushing or cutting of a battery, can result in an explosion.
 - leaving a battery in an extremely high temperature surrounding environment can result in an explosion or the leakage of flammable liquid or gas.
 - a battery subjected to extremely low air pressure may result in an explosion or the leakage of flammable liquid or gas.

3 Installation Quick Guide – Lead-Acid install

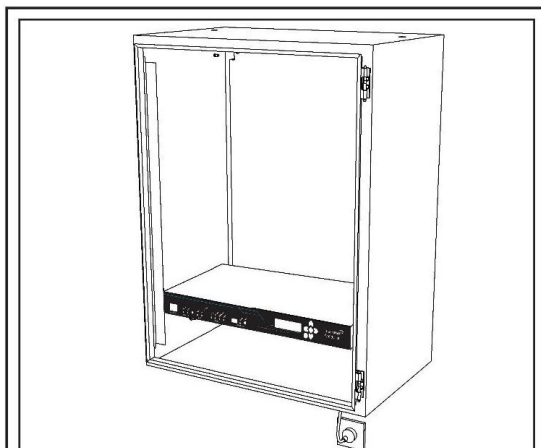

1. Install Controller and power up.

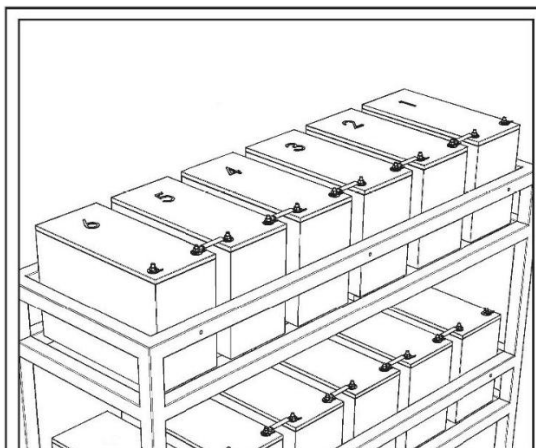

2. Number all blocks individually in a string starting at 1 for each string, e.g. 1-40, 1-40.

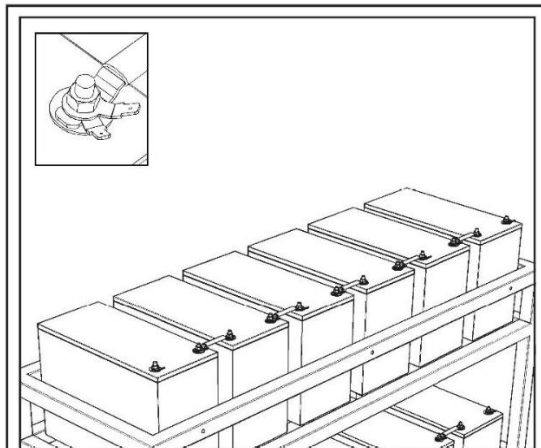

3. Fit 2 terminal tags per post.
Ensure tags are fitted on top of block interlinks.

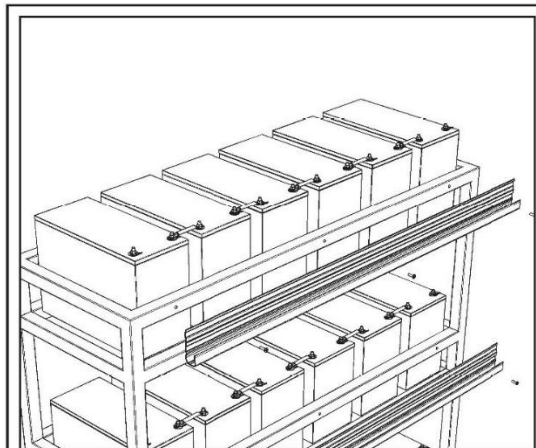

4. Fit mounting rail to suit block and mSensor layout.

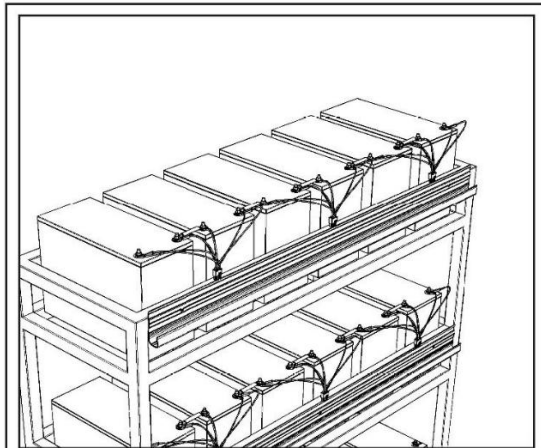

5. Fit mSensor power leads to terminal tags, confirming correct polarity.

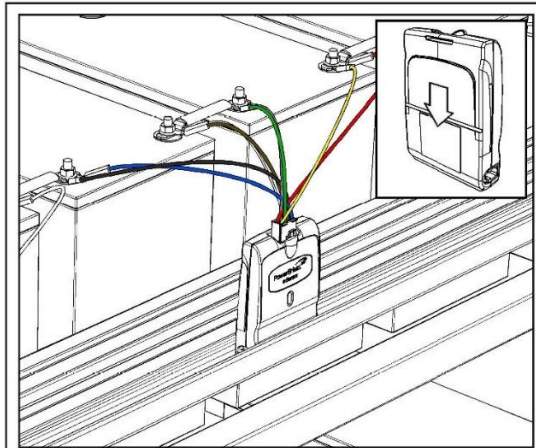

6. Connect mSensors in sequential order of IDs starting at Block 1, e.g. mSensor ID 1 on Block 1 & 2, mSensor ID 2 on Block 3 & 4, etc.

Ensure mSensor LED turns Green.

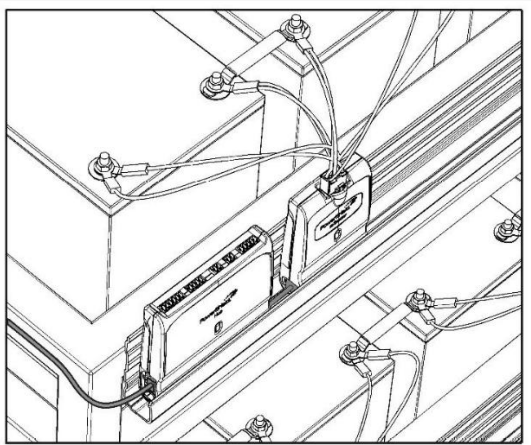

7. Install 1 Hub per String in a convenient location. For multiple strings, install Hubs in sequential order of ID.

Connect port cable from Controller to Hub.
Ensure Hub LED flashes Orange.

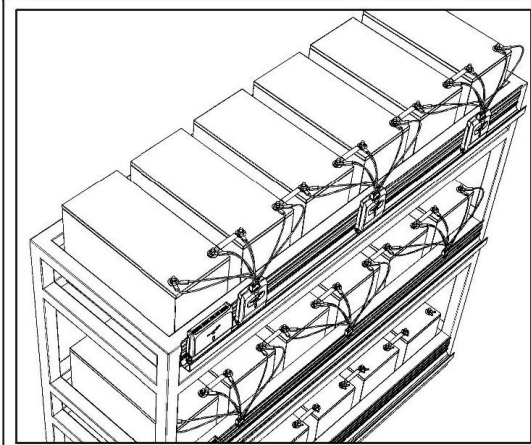

8. Connect BBus cables between Hub and all mSensors. Ensure mSensor LEDs flash Orange.

Remember: Maximum of 32 mSensors per port and all IDs on that port must be different.

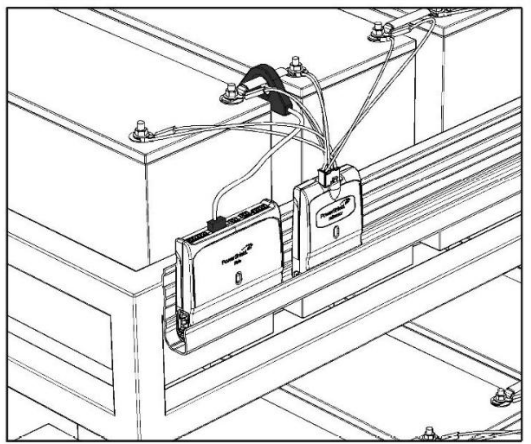

9. Install Current Transducer and connect cable to Hub.

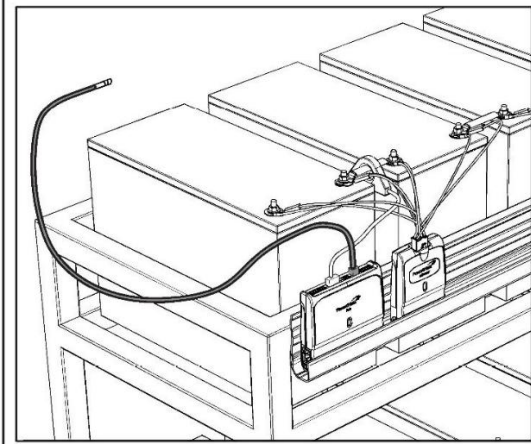

10. Fit Ambient Temperature sensor and connect to Hub.

Note: It is possible to use two Ambient Temperature sensors per Hub.

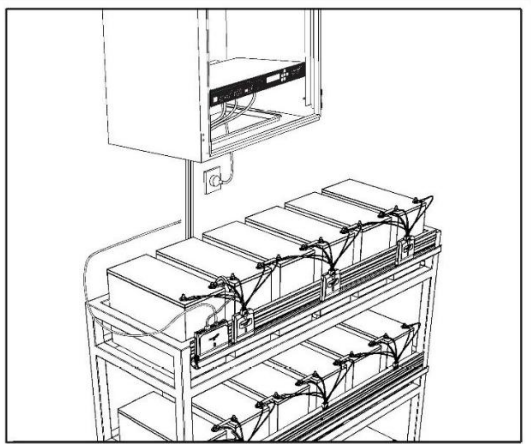

11. Confirm all Hub and mSensor LEDs flash Orange.

Secure all cables tidily.

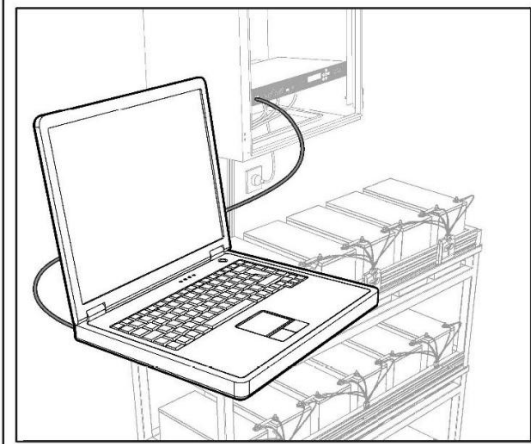

12. Connect to Controller Service Port and configure system as per the System Configuration Manual. Ensure all Hub and mSensor LEDs flash Green when configured.

3.1 Samsung Lithium Installation Quick Guide

The image below shows where you connect the RJ45 Ethernet cable on the rear panel of the Samsung system. This Ethernet cable then connects to the customers network.



Exposed rear panel of a Samsung Lithium system

The image below shows the rear of the PowerShield8 LX Controller, highlighting the RJ45 Ethernet Port. Connect an Ethernet cable from the customers network into 'Ethernet Port 1'.



PowerShield8 LX Controller Rear Panel – RJ45 Ethernet port 1

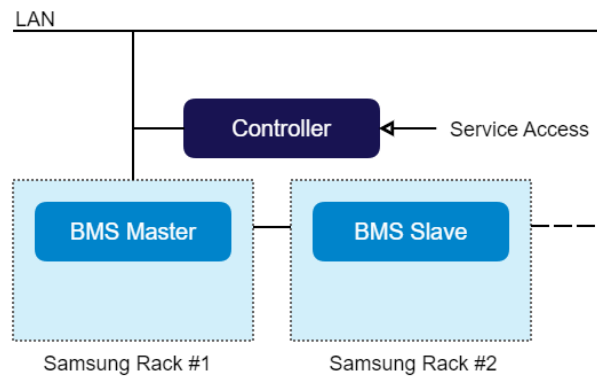

Network diagram detailing where the Controller is connected directly to the network.

Note: This manual covers Lead-Acid installation which mentions other PowerShield hardware that is not applicable for Lithium BMS configurations.

For Lithium BMS configurations, you can disregard information about Hubs, mSensors, Current Transducers, and Ambient Temperature Probe.

4 The PowerShield8 Battery Monitoring System

The *PowerShield8* battery monitoring system is a permanent battery monitoring system that can monitor one or more strings of Lead-Acid(Pb), Nickel Cadmium(Ni-Cd) or Samsung Lithium batteries. System structure varies depending on the battery type being monitored. Parameters measured include:

Lead-Acid Mode	
String Measurements	Voltage, Current, Ripple Current, Ambient Temperature, Ambient Humidity
Block Measurements	Voltage, Ripple Voltage, Ohmic, Temperature

Samsung Lithium Mode	
System	Voltage, Current, SOH, SOC, min/max Temperature and Voltage
Rack Measurements	Voltage, Current, SOH, SOC, Breaker Status, Fuse Status Stat
Module Measurements	Voltage, Voltage Variation
Cell Measurements	Voltage, Temperature

Lead-Acid Mode

The *PowerShield Hub* is used to measure string current, ambient temperature and ambient humidity. The *PowerShield mSensor* is used to monitor each block. The *PowerShield8 Controller* periodically interrogates each *Hub* and *mSensor* and processes the data, logging the information into memory at predefined intervals. The distributed system architecture using local *Hubs* and *mSensors* installed at the battery bank, connected to the *PowerShield8 Controller* using a single CAT5 cable, allows one *PowerShield8 Controller* to monitor multiple remote strings. A single system can also monitor different voltage blocks and strings using appropriate *mSensors*.

Samsung Lithium Mode

The *PowerShield8 Controller* interrogates the Samsung BMS and pulls through battery data and alarms via network connection. A *PowerShield8 Controller* to monitor multiple remote Lithium racks/strings.

PowerShield provides *Link* software for automated multi-site battery management.

PowerShield provides *Assure* for automated multi-site cloud-based battery management.

The diagram on the following page shows an overview of a Lead-Acid system which consists of the following hardware:

- *PowerShield Controller*
- *PowerShield Hubs*
- *PowerShield mSensors*
- Current Transducers
- Ambient Temperature sensors
- Hub-to-BBus adaptors (where applicable)

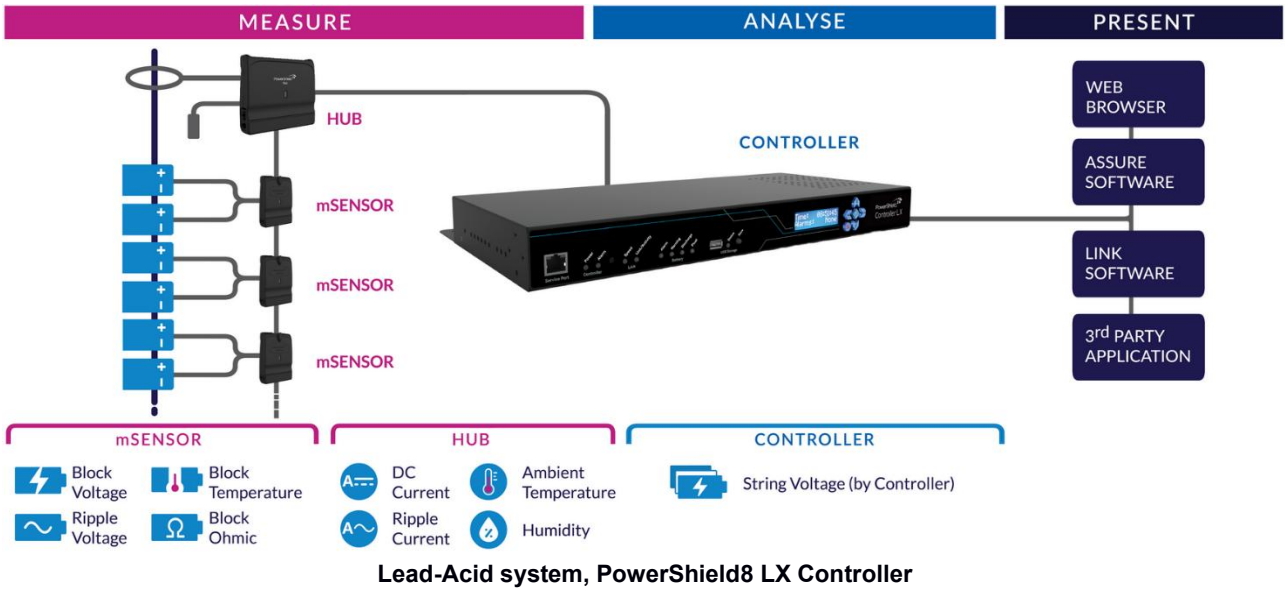

The diagram below shows an overview of a Samsung Lithium system connected to a PowerShield8 Controller:

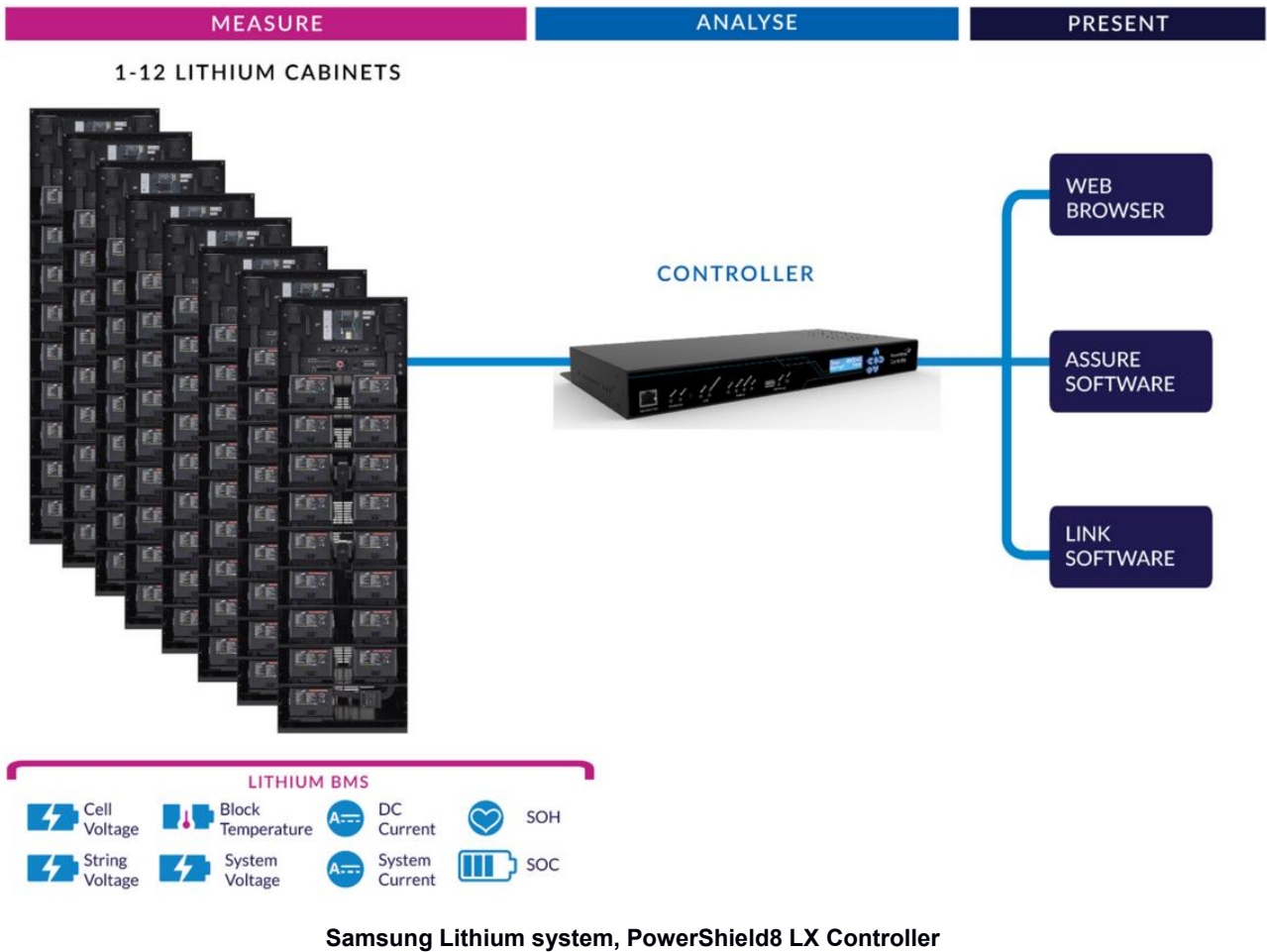

4.2 Controller

There are two versions of *PowerShield8 Controller*:

- *LX Controller*: for larger installations. Can monitor up to 8 strings and up to 512 blocks.
- *MX Controller*: for small to medium sized installations. Can monitor up to 4 strings and up to 200 blocks.

4.2.1 LX Controller

The *PowerShield8 LX Controller* is supplied in a 1U high 19" rack case and can be mounted in a 19" rack, on a wall, shelf, or similar using the mounting brackets provided. Ensure there is safe access to the rear connector panel and cable tray.



The front and rear panels of the *PowerShield8 LX Controller* are shown below.

Refer to Appendix 1 for a description of the front and rear panel features. Refer to Appendix 2 for a description of the front panel LED behaviour.



PowerShield8 LX Controller Front Panel



PowerShield8 LX Controller Rear Panel

4.2.2 MX Controller

The *PowerShield8 MX Controller* is a smaller unit measuring 250mm / 9.8" x 155mm / 6.1" x 36mm / 1.4". It can be mounted on a wall, shelf, or similar and secured in place using the side wings. Alternatively, it can be fitted to a 19" rack using optional mounting brackets or fitted to a DIN rail using optional DIN rail mounting clips. Ensure there is safe access to the rear connector panel.



The front and rear panels of the *PowerShield8 MX Controller* are shown below.

Refer to Appendix 1 for a description of the front and rear panel features. Refer to Appendix 2 for a description of the front panel LED behaviour.



PowerShield8 MX Controller Front Panel



PowerShield8 MX Controller Rear Panel

4.2.3 Power Supply Options

Both versions of *PowerShield Controller* are available in AC input or DC input models.

The AC input model has a standard 3-pin male IEC 60320 C14 appliance inlet.

The DC input models have a male 3-pin input socket and are supplied with a mating female screw terminal plug.

- Both AC and DC models must be installed by a service person and connected to a socket outlet or fixed wiring with a protective earth conductor or connector.
- A readily available disconnect device shall be incorporated in the building wiring or the socket outlet near the *PowerShield Controller* that is readily accessible.
- The power source for the DC models must be fused with a circuit breaker of no greater than 20A rating. The connection must be installed in a service access area.
- To ensure that the system operates during a power failure, it is recommended that the *PowerShield Controller* is powered by a battery backed supply that has sufficient backup time.

4.2.5 Hub Ports and BBus Communication

The *PowerShield Controller* communicates with the *PowerShield Hubs* and *PowerShield mSensors* via the hub ports on the rear panel of the *Controller*. The hub ports use the *BBus* daisy chain communication bus with the devices being connected in series, one after another.

The hub port connectors are 8-pin RJ45 connectors. Standard CAT5 cabling is used to connect the *PowerShield Hubs* to the *PowerShield Controller* via the RJ45 connectors on each device. The *PowerShield Hub* should be the first device on each bus. The cable distance between the *PowerShield Controller* hub port and *PowerShield Hub* should not extend more than 50m (165ft). Contact PowerShield if longer distances are required.

WARNING: An incorrectly terminated CAT5 cable may damage the Controller Hub ports. Before plugging in a non-factory terminated cable check the cable with a network cable tester.

The *PowerShield mSensors* should be connected to the *PowerShield Hub* using 4-core BBus interconnect cable via the 4-pin Modular Jack connectors on each device. The total cable length between the *PowerShield Hub* and last *PowerShield mSensor*, including the short interconnecting BBus cables between each device, should not extend more than 25m (82ft). Contact PowerShield if longer distances are required.

Each *PowerShield Controller* hub port is capable of supporting 1 *Hub* and up to 32 *mSensors*. For strings with a large number of blocks, additional *mSensors* will need to be used. These can be connected to spare *Controller* hub ports using an adaptor available from PowerShield that converts the *Controller* hub port CAT5 cable to 4-core BBus interconnect cable.

4.2.6 Installation

The *PowerShield8* battery monitoring system must be correctly installed and configured in order to obtain accurate results. The installation of the system must be carried out only by suitably trained personnel. Installation must be in an adequately ventilated environment or the warranty may be invalidated.

The *PowerShield8* battery monitoring system operates in a potentially hazardous environment making it imperative that all installation personnel have adequate training and experience. This equipment is not suitable for use in locations where children are likely to be present. The system must be installed in a Service Access area.

Pay particular attention to the following points:

- A) Elevated Operating Ambient Temperature – If installed in a closed or multi-unit rack assembly, the operating ambient temperature of the rack environment may be greater than room ambient. Therefore, consideration should be given to installing the equipment in an environment compatible with the maximum temperature specified in *Appendix 9 – PowerShield Controller Specifications*.
- B) Reduced Air Flow – Installation of the equipment in a rack should be such that the amount of air flow required for safe operation of the equipment is not compromised.
- C) Mechanical Loading – Mounting of the equipment in the rack should be such that a hazardous condition is not achieved due to uneven mechanical loading.
- D) Circuit Overloading – Consideration should be given to the connection of the equipment to the supply circuit and the effect that overloading of the circuits might have on over-current protection and supply wiring. Appropriate consideration of equipment nameplate ratings should be used when addressing this concern.
- E) Reliable Earthing – Reliable earthing of rack-mounted equipment should be maintained. Particular attention should be given to supply connections other than direct connections to the branch circuit (e.g. use of power strips).
- F) Hub Port CAT5 cables – when terminating CAT5 cables use a cable tester to verifying the connection before plugging the cable into the Controller because an incorrectly terminated cable may damage the Controller port.

4.3 Hub



The *PowerShield Hub* is used to connect external sensors for measuring string current and ambient temperature and has an on board ambient humidity sensor. Each *Hub* can read from up to two Current Transducers (depending on model) and up to two Ambient Temperature probes. It also has up to two Dry Contact inputs (depending on model) that can be used to read the state of external devices.

The *PowerShield Controller* communicates with the *Hubs* via the *Controller* hub ports, connected using CAT5 cable. It also supplies 24VDC power to the *Hubs* over this cable. Up to eight *Hubs* can be connected to a single *PowerShield Controller*, 1 per *Controller* hub port. This allows up to eight strings to be monitored with one *PowerShield Controller*.

The *Hub* is also the *BBus* link between the *PowerShield Controller* and *mSensors*. The *mSensors* are connected to the *Hub* using 4-core *BBus* interconnect cable.

Each *Hub* has a factory set ID number in the range 221 to 230. *Hub* ID 221 should be used for the first string and subsequent sequentially numbered *Hubs* are used for multiple string systems (where applicable).

The LED on the *Hub* indicates *Hub* state. Refer to Appendix 2 for *Hub* LED behaviour.

4.4 mSensor



The *PowerShield mSensor* connects to the blocks and periodically measures the block voltage, temperature and ohmic value. Each *mSensor* is specific to the block voltage to which it will be fitted, e.g. 2V / 6V / 12V.

Dual and single *mSensors* are available. A dual *mSensor* is used to monitor a pair of blocks located one after another in series. A single *mSensor* is used to monitor only one block. The *single mSensor* allows for installations containing strings with uneven numbers of blocks or where physical layout makes pairing of blocks impossible. The label on the *mSensor* will show whether it is single or dual.

Each *mSensor* has a factory set ID number. Dual *mSensors* are numbered with IDs in the range 1 to 200 while single *mSensors* are numbered 201 to 220. For ease of mapping of *mSensors* to blocks and subsequent system configuration, it is recommended to connect the *mSensors* to the blocks in sequential order of ID starting at ID 1. Each block in a string must be uniquely identified with a sequential number starting at 1. For correct automatic mapping of *mSensors* to blocks, the block numbering should start at the most positive block in the string. If single *mSensors* are used in a string, they should also be installed in sequential order of ID starting at ID 201.

The *PowerShield Controller* communicates with the *mSensors* via the *Controller* hub ports using the BBus daisy chain communication bus. The *mSensors* should be connected to the *PowerShield Hub* using 4-core BBus interconnect cable via the 4-pin Modular Jack connectors on each device. If a *Hub* is not used, it is possible to connect the *mSensors* to the *PowerShield Controller* using a Hub-to-BBus adaptor that converts the *Controller* hub port CAT5 cable to 4-core BBus interconnect cable.

The LED on the *mSensor* indicates sensor state. Refer to Appendix 2 for *mSensor* LED behaviour.

5 Installation

Complete the forms in Appendix 12 during the installation.

5.1 Install Controller and Power-up

Mount the *PowerShield Controller* securely into a 19" equipment rack (not supplied), wall, shelf, or similar using the appropriate mounting hardware. Refer sections below regarding mounting of the *MX Controller*.

When the *PowerShield Controller* is powered up, it will emit an audible alert and the green Power LED will light. Other LEDs on the front panel may also light.

NOTE: The *Controller* must be installed in a location that allows 30mm space at the top and sides of the unit for adequate air circulation. Installation must allow unrestricted airflow.

Ensure the *Controller* is unable to move when installed – cables and connections must not be strained.

Ensure there is safe access to the rear connector panel.

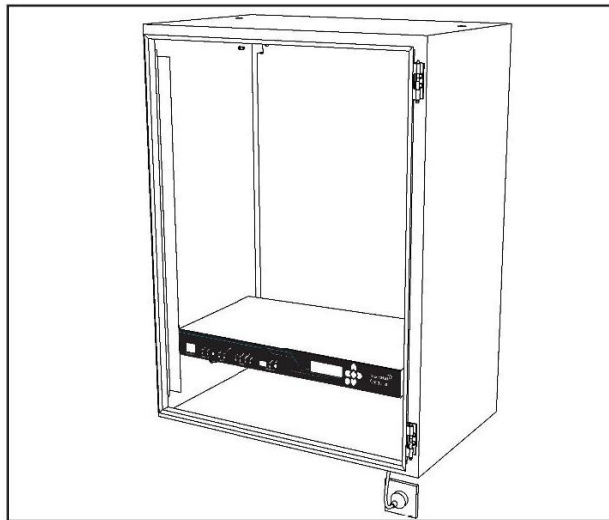

5.1.1 MX Controller Mounting Using Side Wings

The *PowerShield8 MX Controller* has keyhole side wings to allow it to be secured to a suitable robust flat surface. Screws or other fixings are not supplied for use with the side wings as it depends on the material of the surface used.

To mount the *MX Controller* using the side wings complete the following steps:

- Temporarily hold the *MX Controller* in the desired location.
- Trace out each keyhole onto the surface of the location.
- Drill holes at the keyhole locations to suit the mounting screws or fixings (e.g. wall plug, anchor, etc.).
- Insert fixings (if used) and screw in each screw until there is sufficient clearance to allow the keyhole of the *MX Controller* side wings to slide under each screw head.
- Position the *MX Controller* in place and slightly tighten each screw to hold the *MX Controller* firmly in place.

5.1.2 MX Controller Rack Mount Instructions

The *PowerShield8 MX Controller* is supplied with two rack mount brackets and six M3 x 6mm pan head Phillips screws for mounting it into a standard 19" equipment rack. Screws are not provided to secure the brackets to the rack as the size of screws depends on the type of rack used.

To mount the *MX Controller* into a 19" rack complete the following steps:

- Fit a bracket on the each side at the front of the *MX Controller* using the M3 x 6mm screws as shown below.



- Lift the *MX Controller* to the desired location in the rack and secure each bracket to the sides of the rack using two suitable screws (not supplied) as shown below.



5.2 Number Blocks

Each block in string must be uniquely identified with a sequential number starting at 1, e.g. 1-32, 1-40 etc. For ease of mapping of *mSensors* to blocks and subsequent system configuration, it is recommended to start numbering at the most positive block in the string.

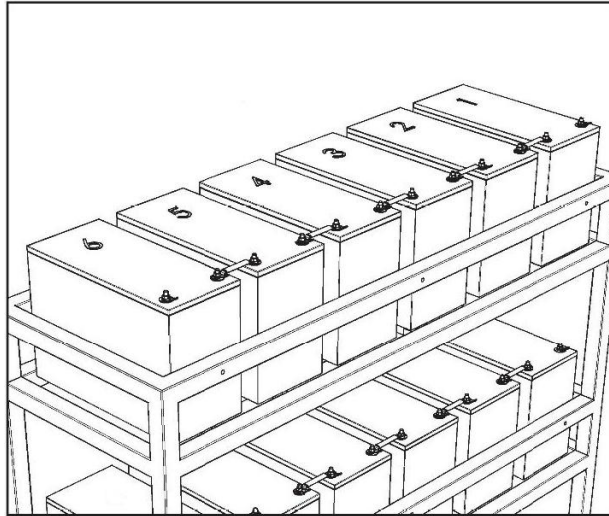

5.3 Block Terminal Tags

Ensure that all blocks have appropriate terminal tags fitted for connection to the *mSensors* as follows. For simplicity, it may be easier and more efficient to fit two tags to every terminal.

- Where a dual *mSensor* is to be used with a pair of blocks, fit two tags on the negative (-) terminal of the most negative block and two tags on the positive (+) terminal of the most positive block. Fit one tag on each of the remaining terminals.
- Where a single *mSensor* is to be used on a single block, fit two tags on all block terminals.

NOTES: The terminal tags must be suitable for 6.3mm x 0.8mm receptacles. The tag material is important for accurate measurements. PowerShield can supply a range of approved tags.

Place the tags on the top of the block interlinks and below any lock washers otherwise the current flow between the interlink and the battery may be reduced and could result in a 'hot spot'.

Do not bend the tags as this can damage the connector crimp and/or result in poor or loose connections with the *mSensor* power leads. Poor connections can have significant impact on impedance measurement. PowerShield reserves the right to void warranties where terminal tags are bent or modified.

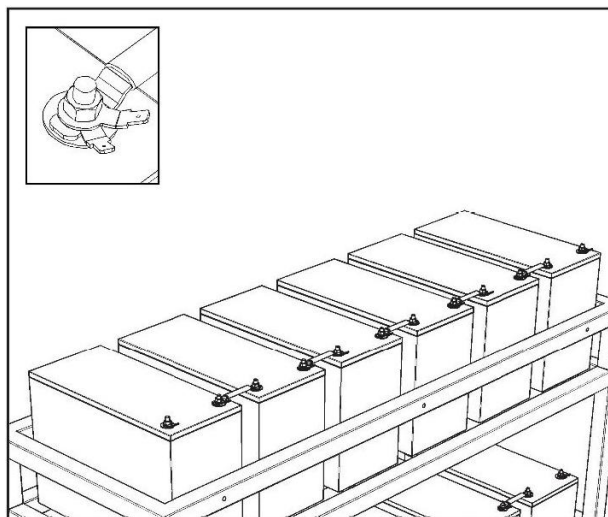

5.4 Mounting Rail for Hubs and mSensors

The mounting rail for the *Hubs* and *mSensors* can be fitted in any orientation and can be used with both battery racks and cabinets. Drill to suit and fasten with screws or cable ties.

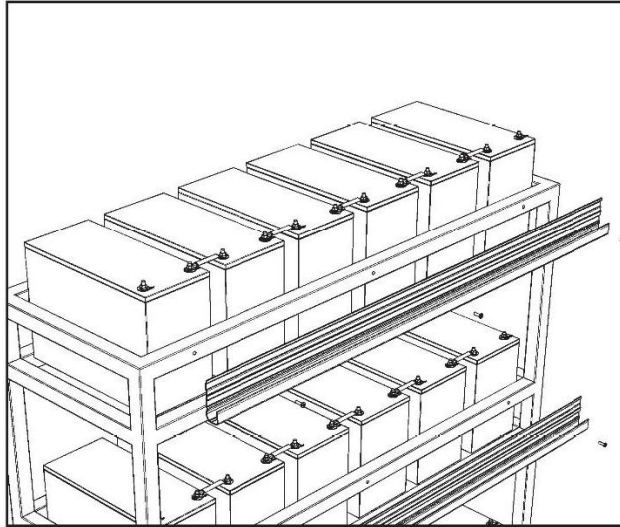

5.5 mSensor Power Leads

Fit the *mSensor* power leads to the block terminal tags with the correct polarity. Ensure the dual power leads are connected across an 'in series' pair of batteries. Power leads are available with or without Block Temperature sensors.

Refer to Appendix 6 for the recommended method of connecting the *mSensor* power leads.

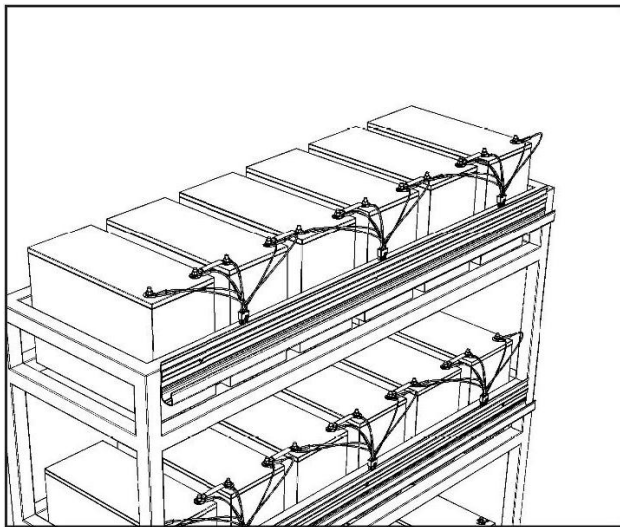

mSensor Power Leads with Block Temperature

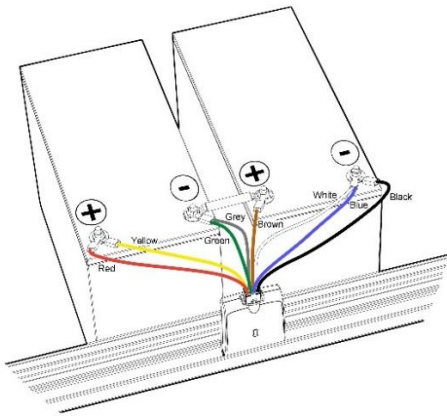

Dual mSensor

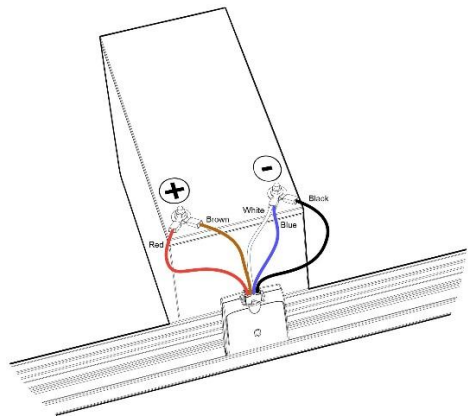

Single mSensor

mSensor Power Leads without Block Temperature

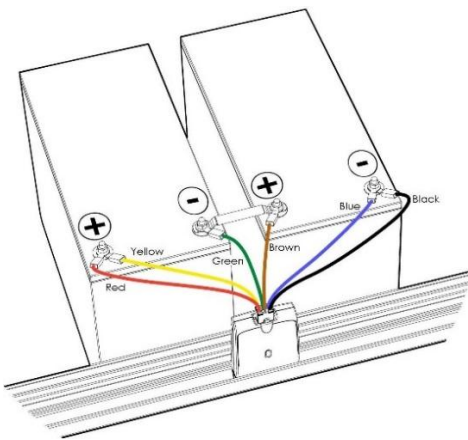

Dual mSensor

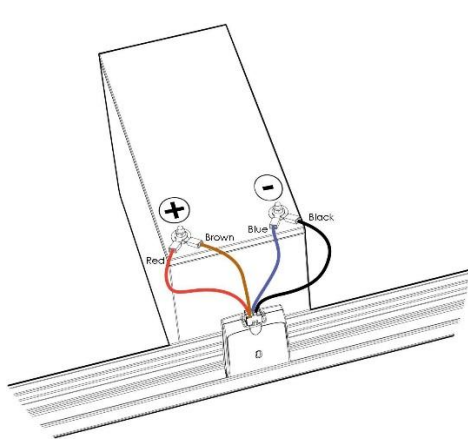

Single mSensor

5.6 Connect mSensors to Blocks

Dual *mSensors* are numbered with IDs in the range 1 to 200 while single *mSensors* are numbered 201 to 220. For ease of mapping of *mSensors* to blocks and subsequent system configuration, it is recommended to connect the *mSensors* to the blocks in sequential order of ID. If single *mSensors* are being used for a string, install these as required but follow the sequential ID order approach.

Plug the *mSensors* onto the power leads of the blocks. The *mSensor* LED should light solid green when the *mSensor* is connected correctly. If the LED lights red, check the connections of the power lead at each block. A full list of *mSensor* LED states is available in Appendix 2.

Insert the *mSensor* into the mounting rail when done.

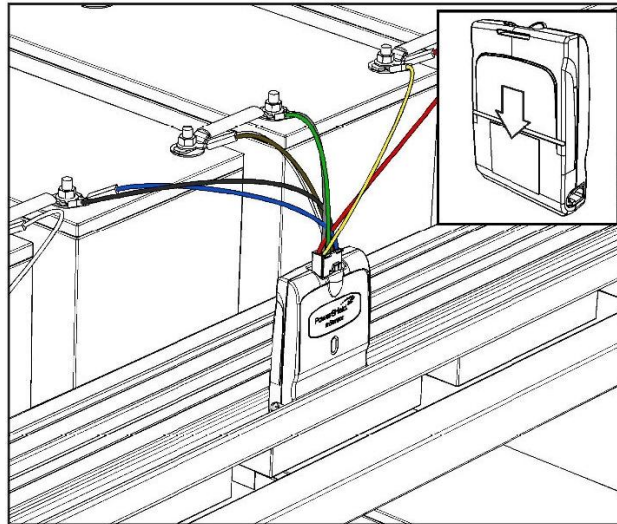

5.7 Install Hub

The number of *PowerShield Hubs* to install depends on the installation design as one *PowerShield Hub* can be used per string or shared across two strings.

PowerShield Hubs are numbered with IDs in the range 221 to 230. Use *Hub* ID 221 for the first string(s) and subsequent sequentially numbered *Hubs* for multiple string systems (where applicable).

Insert the *Hubs* into the same mounting rail as the *mSensors* and connect CAT5 cable from the *PowerShield Controller* hub ports to each *Hub*. The *Hub* LED should flash orange if all is correct. A full list of *Hub* LED states is available in Appendix 2.

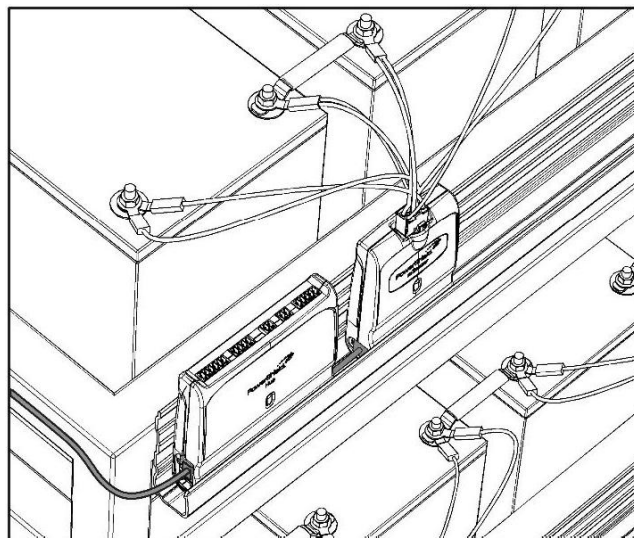

5.8 Connect BBus Cables

Connect the *mSensors* and *Hub* using suitable lengths of BBus interconnecting cables in a daisy chain fashion. Note that each *PowerShield Controller* hub port must not have more than 33 devices connected to it (1 *Hub* and up to 32 *mSensors*). In addition, the IDs of all devices on a single hub port must be different. The same IDs can be used on other hub ports.

For strings with a high number of blocks and *mSensors*, *mSensors* can be connected directly to additional *PowerShield Controller* hub ports using a CAT5-to-BBus adaptor which is available from PowerShield.

The *mSensor* LEDs should flash orange if all is correct. A full list of *mSensor* LED states is available in Appendix 2.

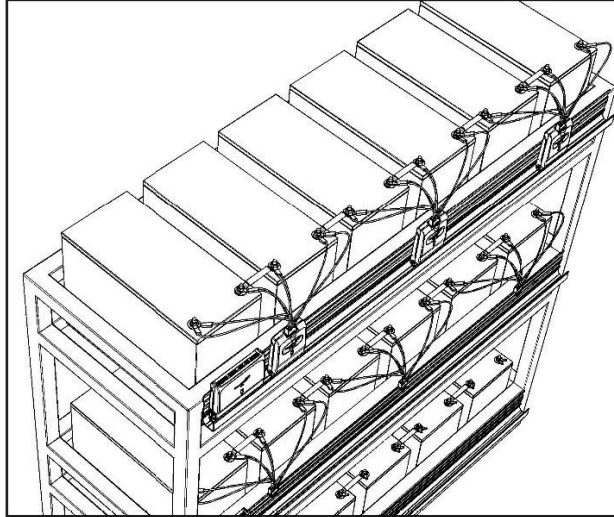

5.9 Install Current Transducer

A current transducer (CT) is required per string to measure string current. Install the current transducer anywhere on the primary string conductor. For a 1 string system, plug the current transducer cable into the *Current 1* connector of the *PowerShield Hub*.

For an installation where a *Hub* is shared across 2 strings, plug the cable from the current transducer installed on the first string into the *Current 1* connector and plug the cable from the current transducer on the second string into the *Current 2* connector. For pinout details refer to Appendix 1 for *PowerShield Hub* pinout.

NOTE: Ensure the current transducer selected has the appropriate rating for the expected string charge and discharge currents. The nominal rating of the current transducer should be similar to the typical maximum expected current flow. The current transducer has a measurement range of $\pm 150\%$ of the nominal rating.

NOTE: When only one current input is used on the Hub always use *Current 1* input as the humidity reading is associated with *Current 1* input only.

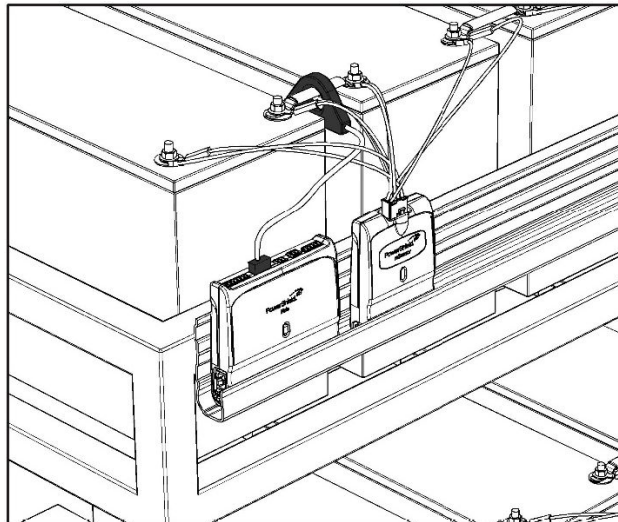

IMPORTANT: The direction of the current transducer is important. The transducer has an arrow on it to show the direction of current flow.

- If the current transducer is installed with its arrow pointing in the direction that current flows during a discharge event, the current transducer direction is considered to be *Standard*.

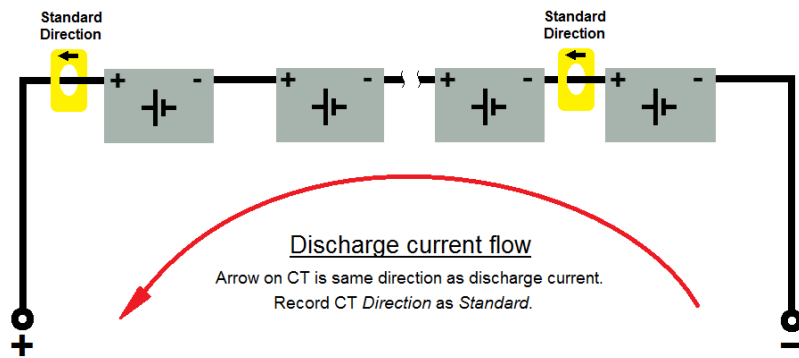

- If the current transducer is installed with its arrow pointing in the direction that current flows during a charge event, the current transducer direction is considered to be *Reversed*.

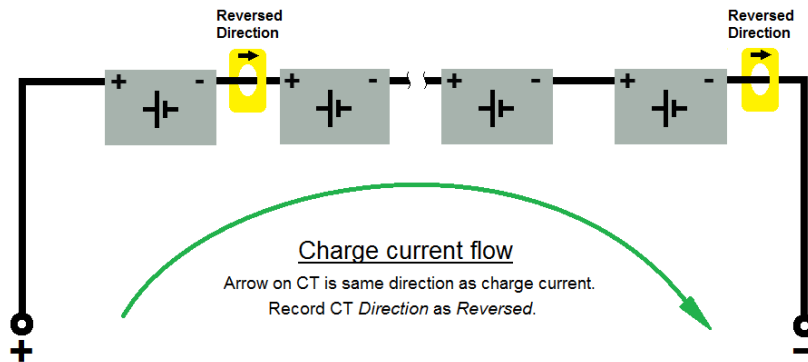

5.10 Connect Ambient Temperature Probe(s)

Up to two ambient temperature sensors can be used with each *Hub* to measure local ambient temperature(s).

Secure the ambient temperature sensor(s) in appropriate locations in or around the battery rack or cabinet but be aware of other factors that may affect the local environment such as HVAC, fans or other devices.

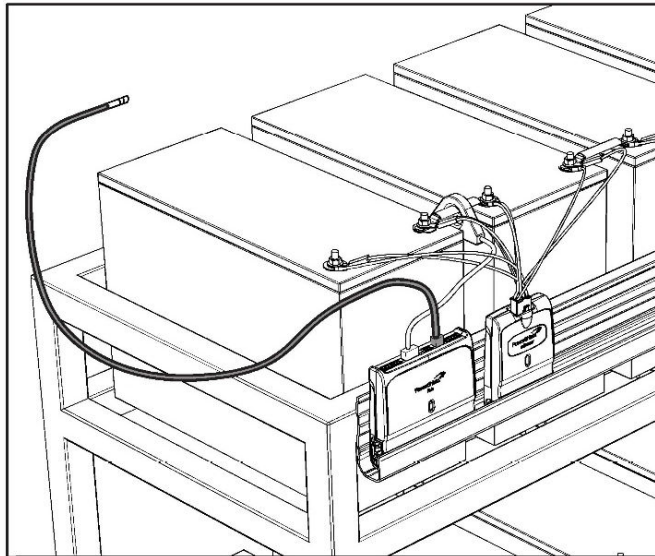

5.11 Confirmation and Configuration

Check that all installed parts are performing as expected and secure all cables with appropriate strain relief.

Complete the forms as in Appendix 12, connect to the *Service Port* connector on the front of the *PowerShield Controller* and configure the system.

Refer to the *PowerShield Controller User Manual* (part number 6300-103) for more details on configuring the system.

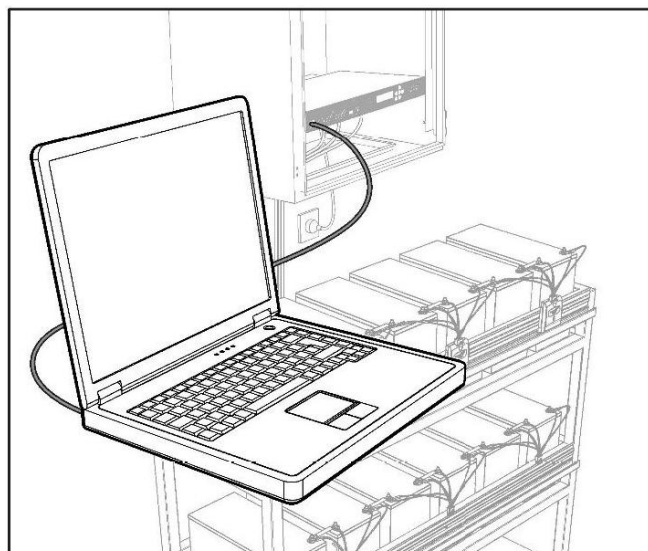

NOTE: All *Hub* and *mSensor* LEDs should flash green if the system is installed and configured correctly.

6 Thermal Runaway Protection

6.1 What is Thermal Runaway?

Thermal runaway occurs in a battery when the rate of internal heat generation exceeds the rate at which the heat can be dissipated into the ambient environment. If the battery cannot dissipate the excess heat, its internal temperature will rise continuously which can cause the case of the battery to rupture.

6.2 How is Thermal Runaway Prevented?

Thermal runaway is detected by monitoring block and ambient temperatures. If these exceed certain limits, the *PowerShield8* battery monitoring system will raise alarms to signal that thermal runaway has been detected.

A control output signal can also be issued to prevent thermal runaway from progressing by using the Thermal Runaway Protection feature. By default, only alarms are raised. For a control signal to be sent Thermal Runaway Protection must be enabled and configured. Refer to the *PowerShield8 Configuration Manual* on how to enable and configure the Thermal Runaway Protection feature

The *PowerShield8* battery monitoring system can implement two methods to prevent thermal runaway – *Controller Method* and *Hub Method*.

6.2.1 Controller Method

The *Controller Method* is designed to be used with a charger signalling system. This method uses a relay in the *PowerShield Controller* to signal the UPS to step down the charge voltage to prevent thermal runaway from progressing.

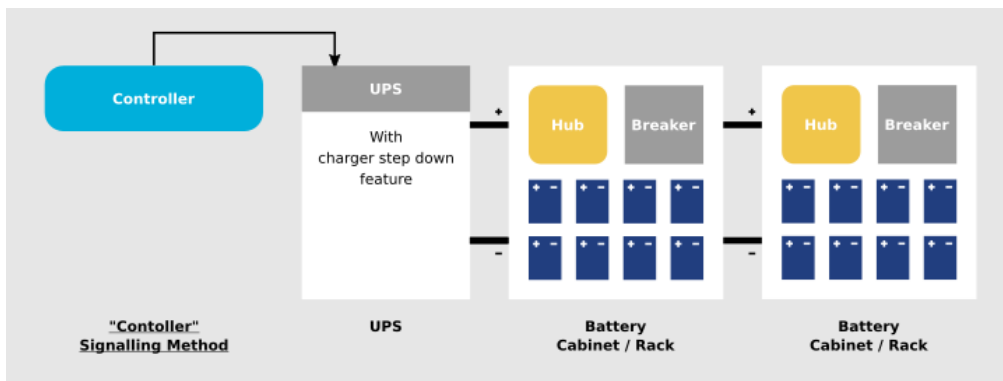

This method uses Relay #1 on a MX Controller or Relay #2 on a LX Controller as a *Signalling* relay to signal the UPS to step down the supply voltage. Relay #1 on a LX Controller can optionally be used as a *Warning* relay to signal auxiliary equipment that the *PowerShield8* system has detected thermal runaway but has not yet acted on it. Refer diagram below.

There is a default delay of 8hrs delay between the *Warning* relay activating and the *Signalling* relay activating. This way, the *Warning* relay can indicate that thermal runaway has been detected and allow local action to be taken to prevent the thermal runaway. If the conditions for thermal runaway continue beyond the warning period, the *Signalling* relay will be activated to signal the UPS to step down the string voltage.

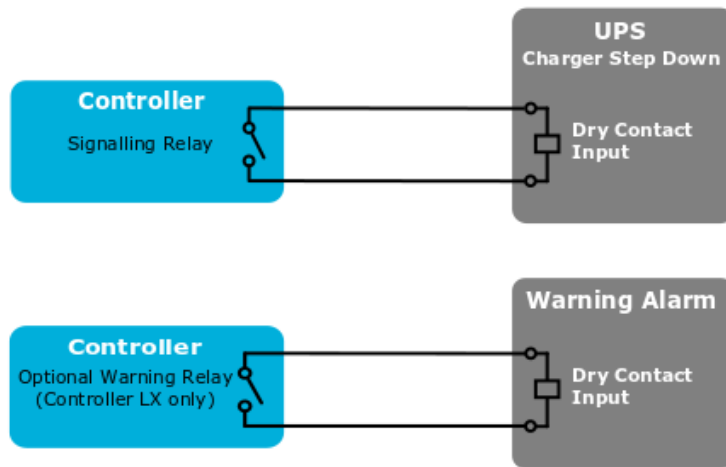

Controller Signalling is the preferred method of preventing thermal runaway because:

- It is the least complicated in terms of installation.
- No strings are taken offline so there is no effect on system backup time compared to the *Hub Method*.

6.2.2 Hub Method

The *Hub Method* is designed to be used with a String Breaker signalling system. This method uses the relay located in a *PowerShield Hub* to trip the string breaker and take the string offline.

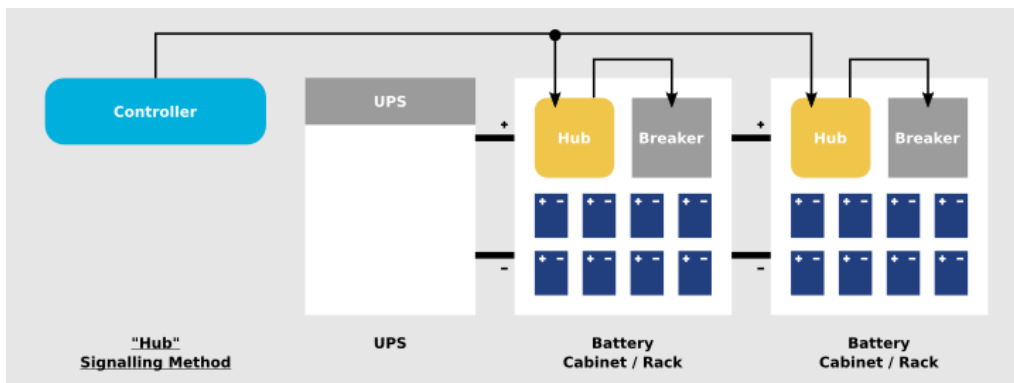

With the *Hub Method*, the relay of a *PowerShield Hub* is used to activate the string breaker and take the string offline. Note that this method requires a source of power for the trip coil of the string breaker.

A *Controller* relay can be used in series with the *Hub* relay as an extra safeguard against false triggering of the string breaker. With this scheme, both the *Controller* and *Hub* relays need to activate before the string breaker is tripped.

Alternatively, the *Controller* relay can be used to raise a warning alarm to signal auxiliary equipment that the *PowerShield8* system has detected thermal runaway but has not yet acted on it. With this scheme, the *Controller* relay is considered a *Warning* relay and the *Hub* relay is considered a *Signalling* relay.

There is a default delay of 8hrs delay between the *Warning* relay activating and the *Signalling* relay activating. This way, the *Warning* relay can indicate that thermal runaway has been detected and allow local action to be taken to prevent the thermal runaway. If the conditions for thermal runaway continue beyond the warning period, the *Signalling* relay will be activated to signal the UPS to step down the string voltage.

There is a number of ways how the *Controller* and *Hub* relays can be used. Some examples are shown below. In all cases, the ratings of the *Controller / Hub* relay contacts must not be exceeded. If the ratings will be exceeded, interposing relays can be used that have appropriate ratings for the device being switched or if galvanic isolation is required between the *Controller / Hub* relays and the device being switched.

IMPORTANT: If the *Controller / Hub* relay contacts are connected to an inductive load that may cause a high voltage 'kick back' or 'fly back' transient when it is switched, appropriate external suppression should be fitted across the load.

Example 1: Hub method with Controller warning relay and Hub signalling relay in series.
String Breaker rating does not exceed the contact ratings of *Controller / Hub* relays.

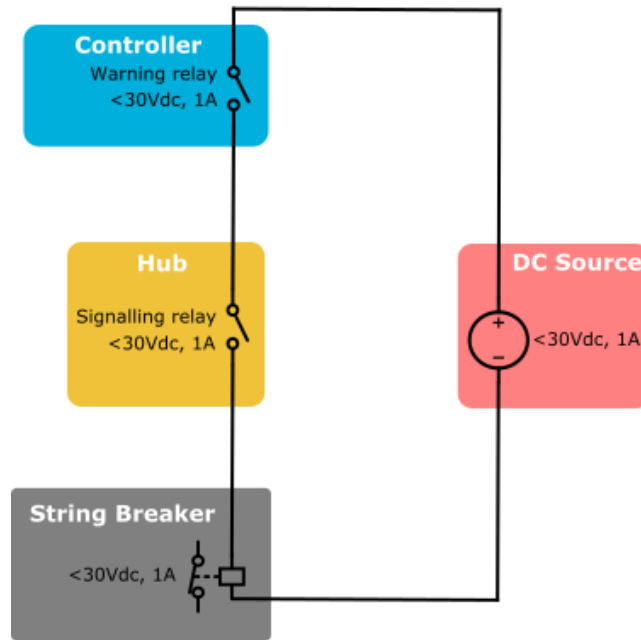

Example 2: Hub method with Controller relay used for optional alarm.
String Breaker rating does not exceed the contact ratings of *Hub* relay.

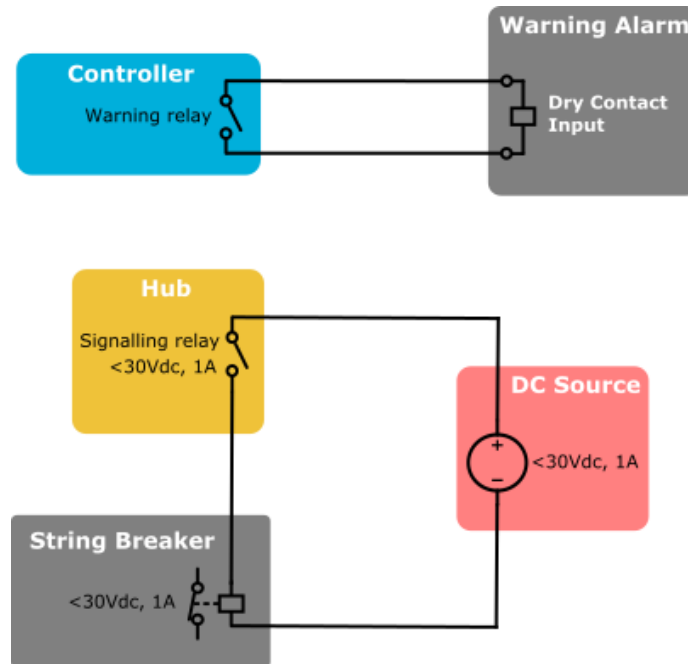

Example 3: Hub method with high current interposing relay.
 Current of string breaker trip coil exceeds contact ratings of *Hub* relay so an interposing relay with high current contacts is used.
 Coil rating of interposing relay does not exceed contact ratings of *Hub* relay.

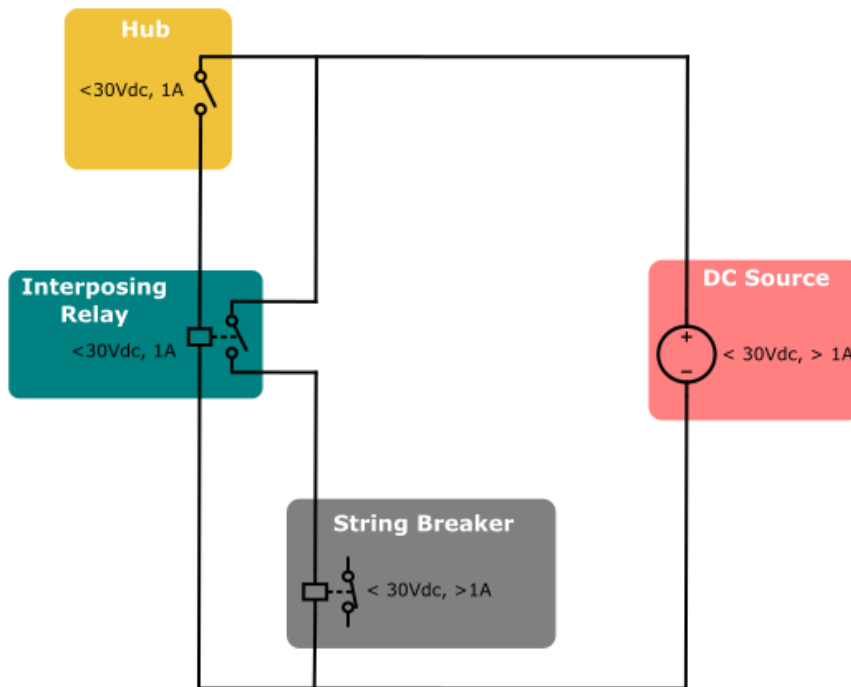

Example 4: Hub method with high voltage interposing relay.
 Voltage of string breaker trip coil exceeds contact ratings of *Hub* relay so an interposing relay with high voltage contacts is used. Note that a 2nd voltage source is required for the supply of the string breaker trip coil. This may be available from the UPS (as shown below).
 Coil rating of interposing relay does not exceed contact ratings of *Hub* relay.

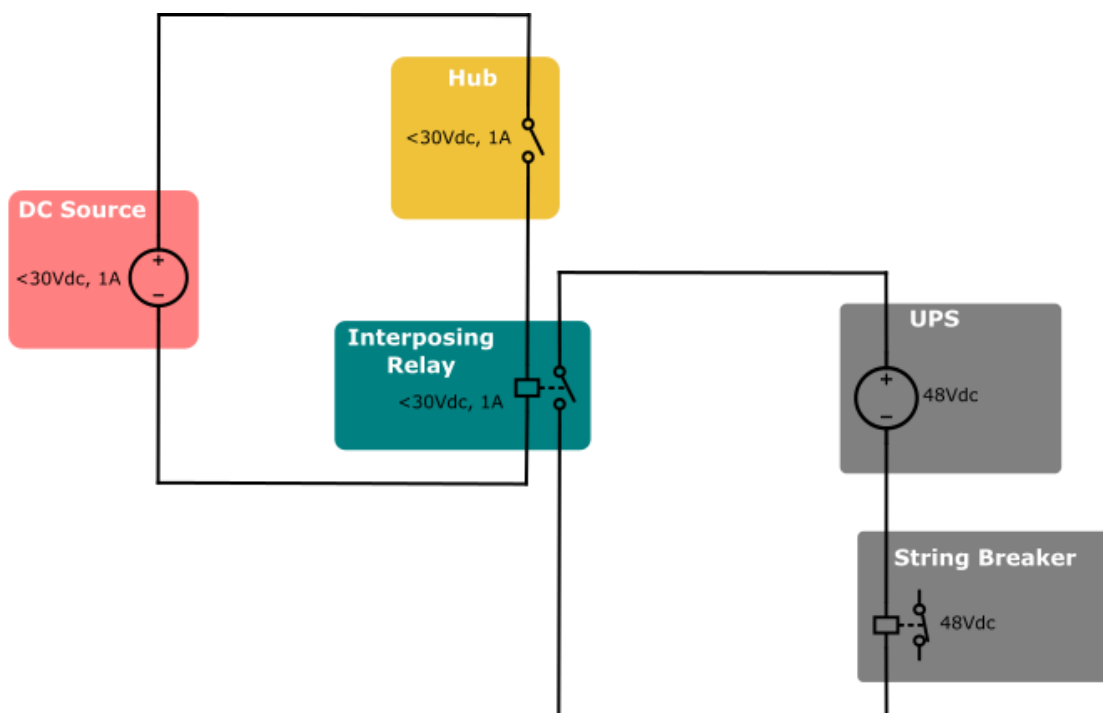

Example 5: Hub method with UPS control of breaker in parallel.

In some installations, the UPS can activate the string breaker in parallel to the *Hub* relay. It may also use a different voltage than that used with the *Hub* relay or it may only provide power to activate the trip coil of the string breaker at external terminals (it does not make its internal power source available externally). In this situation, diodes are required to isolate the external DC source & *Hub* relay from the UPS as shown below.

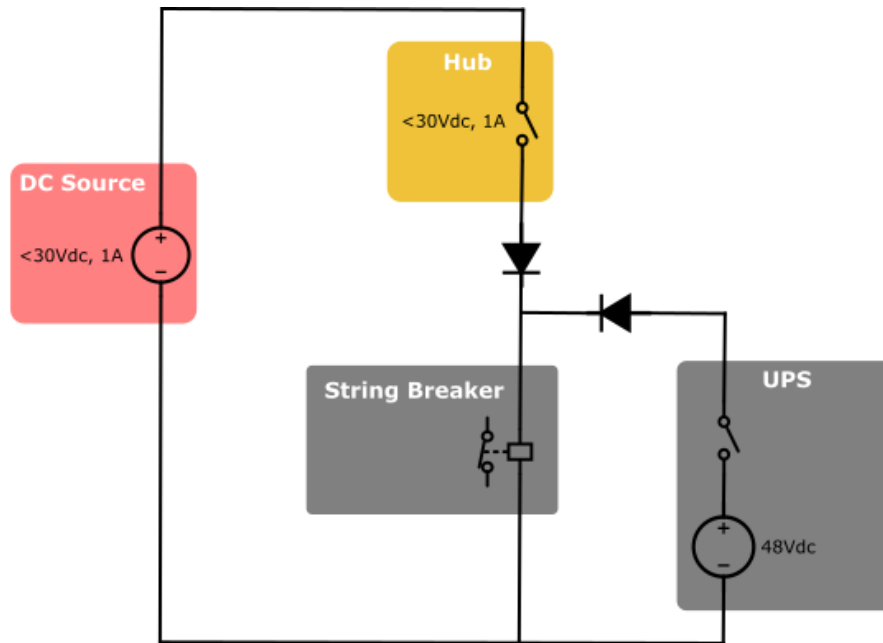

6.2.3 Location of Ambient Temperature Probe

Thermal runaway is detected by monitoring block and ambient temperatures. If these exceed certain limits, the *PowerShield8* battery monitoring system will raise alarms to signal that thermal runaway has been detected.

The location of the ambient temperature sensor(s) is important for accurate thermal runaway prevention. It is recommended to place ambient temperature sensor(s) near the bottom and middle of the string in order to avoid heat that may be generated by the blocks.

Secure the ambient temperature sensor(s) in appropriate locations in or around the battery rack or cabinet but be aware of other factors that may affect the local environment such as HVAC, fans or other devices.

Appendix 1 – Controller Panels & Hub Pinouts

LX Controller Front Panel



The front panel of the *PowerShield8 LX Controller* has the following features:

- Service Port: This port can be used to temporarily connect to the *Controller* on site. It uses an RJ45 Ethernet connector.
- LEDs: These indicate system behaviour. Refer to Appendix 2 for a description of the LED states.
- USB Port: The USB Port can be used to copy *Controller* data and configuration files to a USB Flash Drive (FAT or FAT32 file system format required).
- USB Save Button: This button is used to start the copying of files to the USB Flash Drive.
- LCD: The LCD displays some system information. Navigation is via the 6-key keypad. Refer to Appendix 3 for a description of the LCD menu system and information displayed.

LX Controller Rear Panel



The rear panel of the *PowerShield8 LX Controller* has the following features (viewed from right to left):

- Port 1: This is an Ethernet port that is intended as a permanent LAN connection for the *Controller*. The behaviour of the LEDs are as follows:

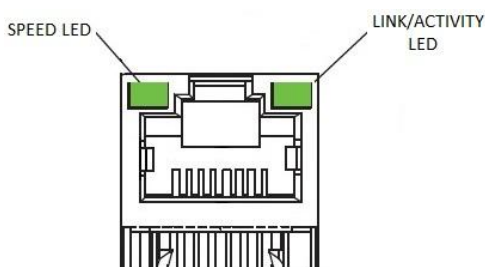

Name	Colour	Description
Speed	Green	On if LAN connection is operating at 1Gbps.
Link/Activity	Green	On if LAN Ethernet link is up. Flashes during activity.

- Port 2 & 3: These ports are for optional communication devices. Refer to Appendix 4 for more details.

- Relays: The *PowerShield8 LX Controller* has 4 relays that can be used to control or trigger external devices when certain events occur. Refer to Appendix 5 for details of the relay terminals.
- Auxiliary Inputs: The *PowerShield8 LX Controller* has 2 dry contact inputs that can be used to read the state of external devices. Refer to Appendix 5 for details of the Auxiliary Inputs.
- Hub Ports: The *PowerShield8 LX Controller* has 8 hub ports that can be used to communicate with *Hubs* or *mSensors*. The behaviour of the LEDs on each hub port are as follows:

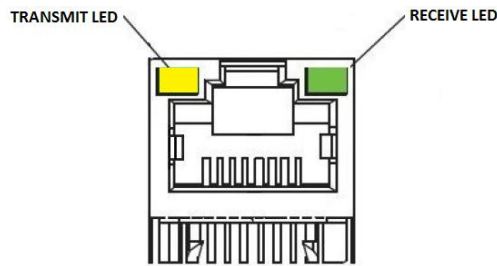

Name	Colour	Description
Transmit	Yellow	Flashes when the <i>Controller</i> is transmitting data.
Receive	Green	Flashes when the <i>Controller</i> is receiving data.

- Power Connector: The *Controller* is available in AC input or DC input models. The AC input model has a standard 3-pin male IEC 60320 C14 appliance inlet as shown below:

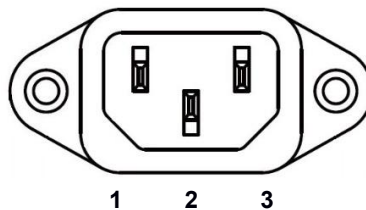

Pin	Function
1 (Left)	Neutral
2 (Centre)	Earth
3 (Right)	Live

The DC input models are fitted with a male 3-way input socket as shown below:

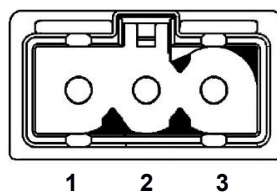

Pin	Function
1 (Left)	DC supply positive
2 (Centre)	Earth
3 (Right)	DC supply negative

The DC input models are supplied with a mating female screw terminal plug. Refer to Appendix 8 for wiring details of the DC input model plug.

- Cable Tray: The case features a cable tray that extends beyond the rear panel connectors. Cables can be secured to the cable tray to prevent them being accidentally unplugged and provide some strain relief.

MX Controller Front Panel



The front panel of the *PowerShield8 MX Controller* has the following features:

- Service Port: This port can be used to temporarily connect to the *Controller* on site. It uses a USB Type B connector.
- LEDs: These indicate system behaviour. Refer to Appendix 2 for a description of the LED states.
- SD Card: The SD Card can be used to copy *Controller* data and configuration files to an SD card (FAT or FAT32 file system format required).
- Save Button: This button is used to start the copying of files to the SD card.

MX Controller Rear Panel



The rear panel of the *PowerShield8 MX Controller* has the following features (viewed from right to left):

- Port 1: This is an Ethernet port that is intended as a permanent LAN connection for the *Controller*. The behaviour of the LEDs are as follows:

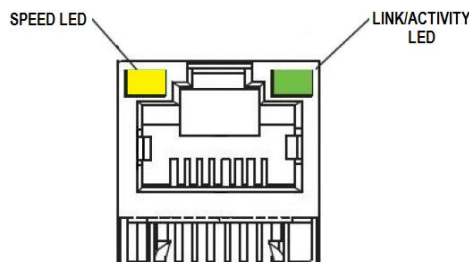

Name	Colour	Description
Speed	Yellow ¹	On if LAN connection is operating at 100Mbps ² .
Link/Activity	Green	On if LAN Ethernet link is up. Flashes during activity.

1. LED colour may be Green on some models.
 2. From July 2022 onwards, Speed LED may always be off irrespective of LAN connection speed. This is due to a change in the LED control module and is beyond our control.

- Port 2: This port is for optional communication devices. Refer to Appendix 4 for more details.
- Relay: The *PowerShield8 MX Controller* has 1 relay that can be used to control or trigger external devices when certain events occur. Refer to Appendix 5 for details of the relay terminals.

- Temp.: The *PowerShield8 MX Controller* has 1 Ambient Temperature input that allows an external sensor to be connected to measure ambient temperature. Refer to Appendix 5 for details of the Ambient Temperature input.
- Hub Ports: The *PowerShield8 MX Controller* has 4 hub ports that can be used to communicate with *Hubs* or *mSensors*. The behaviour of the LEDs on each hub port are as follows:

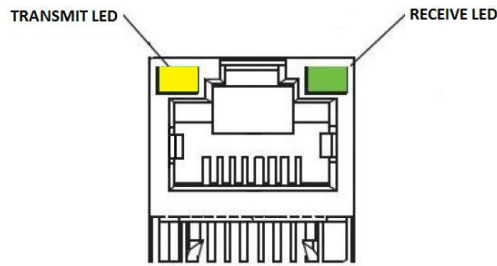

Name	Colour	Description
Transmit	Yellow	Flashes when the <i>Controller</i> is transmitting data.
Receive	Green	Flashes when the <i>Controller</i> is receiving data.

- Power Connector: The *Controller* is available in AC input or DC input models. The AC input model has a standard 3-pin male IEC 60320 C14 appliance inlet as shown below:

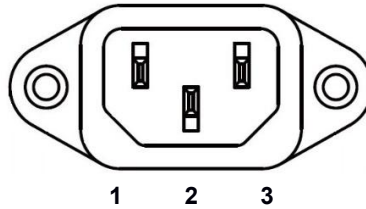

Pin	Function
1 (Left)	Neutral
2 (Centre)	Earth
3 (Right)	Live

The DC input models are fitted with a male 3 way input socket as shown below:

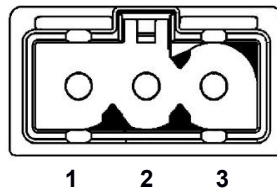

Pin	Function
1 (Left)	DC supply positive
2 (Centre)	Earth
3 (Right)	DC supply negative

The DC input models are supplied with a mating female screw terminal plug. Refer to Appendix 8 for wiring details of the DC input model plug.

Hub Pinout

The *PowerShield Hub* has 4 models distinguished by its functionality and pinouts:

1. Part Number 9100-200

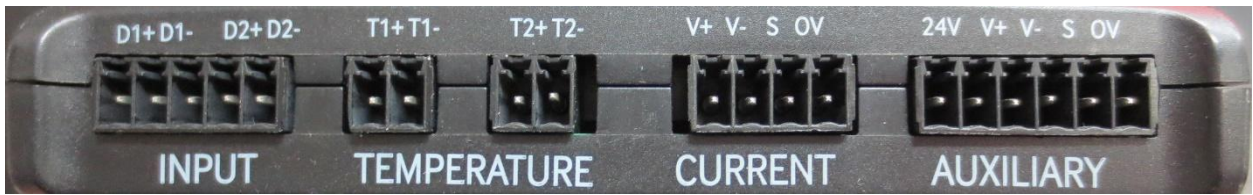

2. Part Number 9100-201

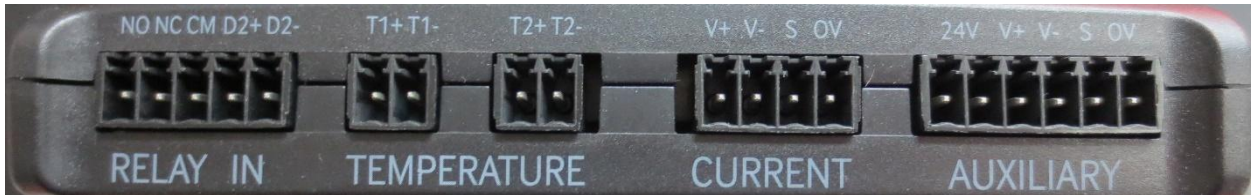

3. Part Number 9100-201-1 / 9100-201-2 / 9100-201-3

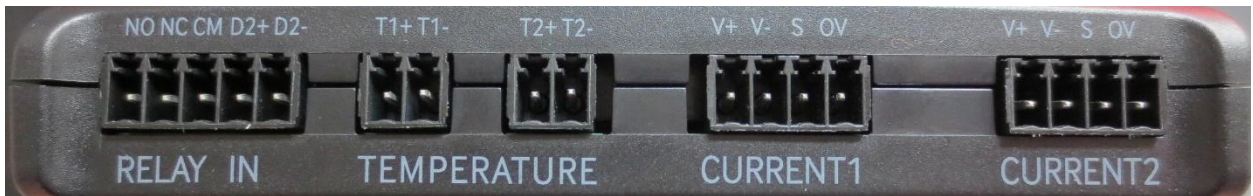

Models of *PowerShield Hub*:

Part number	Features	
	Input	Output
9100-200	2 Digital, 2 Ambient Temp, 1 Current, 1 Aux	-
9100-201	1 Digital, 2 Ambient Temp, 1 Current, 1 Aux	1 Relay
9100-201-1	1 Digital, 2 Ambient Temp, 2 Currents*	
9100-201-2	1 Digital, 2 Ambient Temp, 2 Currents	
9100-201-3		

*Current ripple measurement in Single Mode only on Current Input 1

Field replacement compatibility:

- 9100-201-3, 9100-201-2 & 9100-201-1 can be used to replace 9100-201
- 9100-201-3, 9100-201-2 can be used to replace 9100-201-1
- 9100-201-3 can be used to replace 9100-201-2

9100-201-1 requires *Controller* software v2.5 or later, 9100-201-2 required *Controller* software v2.6 or later, 9100-201-3 required *Controller* software v2.7 or later.

Appendix 2 – LED Behaviour

PowerShield Controller LEDs

The *PowerShield Controller* has LEDs on the front panel for on-site information. They will exhibit varying behaviour as described below:

Name	Colour	Description
Controller Power	Green	On continuously when powered.
Controller Alarm	Red	On continuously if the PowerShield Controller has an internal system fault. Should be off under normal circumstances.
LAN Speed (LX Controller only)	Green	On if LAN connection is operating at 1Gbps.
LAN Link/Activity (LX Controller only)	Green	On if LAN Ethernet link is up. Flashes during activity.
Battery Alarm	Red	On if there is a battery or string alarm.
Battery Warning	Orange	On if there is a battery or string warning.
Battery Discharge (LX Controller only)	Orange	On if all strings are in discharge. Flashes if one or more strings in discharge.
Battery Float (LX Controller only)	Orange	On if all strings are in float. Flashes if one or more strings in float.
USB Status (LX Controller only)	Orange	Off if there is no external USB device present or when it is safe to unplug the device. On if the USB device is ready for use. This state should occur shortly after a device has been plugged in and detected successfully. Flashes during activity. Note: Pressing the USB Save button also affects the state of the USB Status LED.
SD Card Status (MX Controller only)	Orange	Off if there is no SD Card present or when it is safe to eject the card. On if the SD Card is ready for use. This state should occur shortly after a device has been inserted and detected successfully. Flashes during activity. Note: Pressing the SD Card Save button also affects the state of the LED.

mSensor and Hub LEDs

The *mSensor* and *Hub* have tri-colour LEDs that will exhibit varying behaviour as described below. The behaviour is the same for both devices.

Colour	State	Description
Green	Continuous	Device is connected correctly. For an mSensor, this indicates that the sensor is connected correctly to the batteries being monitored and the battery voltages are appropriate.
Red	Continuous	Device is not connected correctly or has a fault. For an mSensor, this may indicate that the sensor has detected a problem with the wiring harness or battery.
Orange	Continuous	Device is in locate mode.
Green	Single Flash	Device is detected and operating as normal.
Orange	Double Flash	Device is receiving communication but has not been detected by the <i>PowerShield Controller</i> .
White	Continuous	Applies to <i>Hub</i> only. Device is in boot loader mode and waiting for commands.
White	Single Flash	Applies to <i>Hub</i> only. Device is in boot loader mode and updating firmware.

Notes:

Single Flash = On for 0.25s, off for 3.75s.

Double Flash = On for 0.25s, off for 0.25s, on again for 0.25s and then off for 3.25s.

Appendix 3 – LX Controller LCD

The *PowerShield8 LX Controller* LCD can be used to view system information. The information is displayed by pressing the keypad buttons to access the required levels as shown below. The buttons operate as follows:

- Use the ▲ ▼ ◀ ▶ buttons to scroll through the menu levels.
- Use the ✓ button to select a level.
- Use the ✕ button to return to the previous level.
- The menu system is shown below:

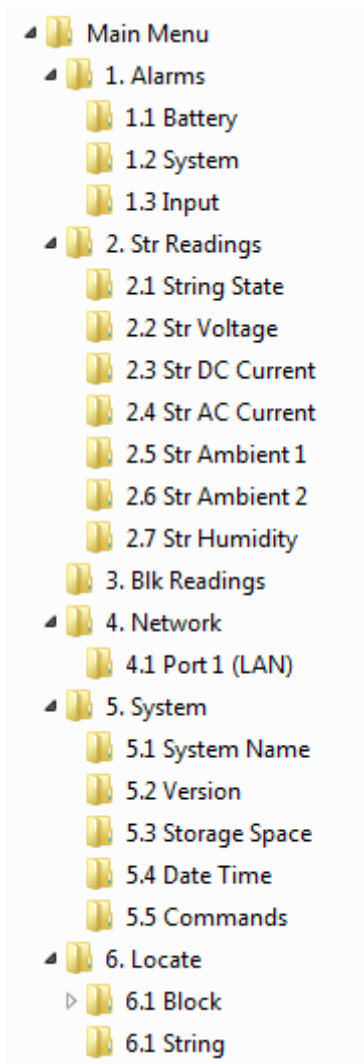

Appendix 4 – Communication Options

The *PowerShield Controller* has slots for optional communication cards. The connectors for these cards will be fitted to either the Port 2 or Port 3 openings in the rear panel.

These cards offer an optional way of communicating with the *PowerShield Controller* using a MODBUS RTU protocol.

Refer to the *PowerShield Controller User Manual* (part number 6300-103) for details of how to configure the cards.

RS-485

The RS-485 card implements 2-wire (half-duplex) transmission. The RS-485 signals can be accessed at the 4-way screw terminal connector on the rear panel of the *PowerShield Controller* as shown below. If more than one Slave is on the RS-485 bus, connect the additional Slaves using a daisy-chain approach and join the signal wires at the 4-way connector.

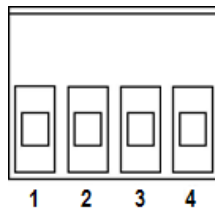

Pin	Name	Function
1, 4	Common (C)	Common signal reference ground for RS-485 differential pair. This should be connected to the ground of the Master device for correct signal level translation and to limit common mode voltages.
2	Data+ (A)	Positive signal of RS-485 differential data pair (Non-inverting Receiver Input A / Driver Output A).
3	Data- (B)	Negative signal of RS-485 differential data pair (Inverting Receiver Input B / Driver Output B).

Cabling & Termination

The diagram below illustrates a RS-485 Master with multiple Slaves.

It is recommended to use twisted pair wire for the RS-485 signals for improved noise immunity.

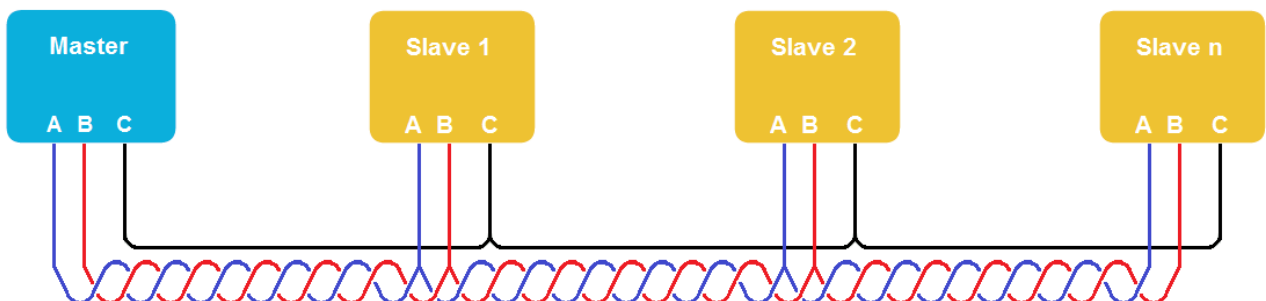

For long cable runs or where signal reflections are an issue, it is good practice to terminate the signal wires at each end of the cable with a resistor equal to the characteristic impedance of the cable. A typical value for 24 AWG twisted pair cable is 120Ω.

To terminate the cable at the *PowerShield Controller*, fit a suitable resistor between pins 2 & 3 of the 4-way connector.

Appendix 5 – Relays, Auxiliary Inputs and Ambient Temperature

Relays

The *PowerShield Controller* relay that can be used to trigger a piece of external equipment when certain events are detected. For example, a relay could be used to turn on a light, sound a beeper or trigger an input to a SCADA/Building Management System when the event occurs. The relay will be in its normal state when the event it is associated with is not active. If the event occurs, the relay will be activated.

The relays are Single Pole Double Throw relays and have 3 terminals as shown below (illustration shows relay in not activated state). The relay terminals can be accessed at the rear panel of the *PowerShield Controller* using screw terminal connectors.

The relay contacts are rated for 1A, 30VDC. They must not be used to switch higher, AC or DC, voltages.

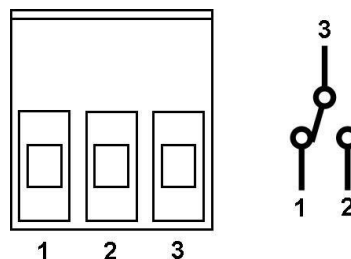

Pin	Name	Function
1	Normally closed contact	The Common Contact is connected to this pin when the relay is not activated. Connect external circuit to this pin and the Common Contact if you want the circuit to be on when the relay <i>is not</i> activated.
2	Normally open contact	The Common Contact is connected to this pin when the relay is activated. Connect external circuit to this pin and the Common Contact if you want the circuit to be on when the relay <i>is</i> activated.
3	Common contact	Connects to Normally Open or Normally Closed contact depending on relay state.

Auxiliary Inputs (LX Controller only)

The *PowerShield8 LX Controller* has two auxiliary inputs that can be used to read the state of a dry contact switch in third party equipment. To activate the auxiliary input simply short the terminals of the non-polarised two way connector.

Ambient Temperature (MX Controller only)

The *PowerShield8 MX Controller* has one ambient temperature input that allows an external thermistor temperature sensor to be connected to measure ambient temperature. To use the ambient temperature input simply plug in a *PowerShield Ambient Temperature* sensor.

Appendix 6 – mSensor Power Lead Connection

It is important to connect and install the *mSensor* power lead correctly. The following diagrams show the recommended method of connecting an *mSensor* to blocks with 2 or 4 terminals per block.

Failure to connect and install the *mSensor* power lead correctly may lead to unacceptable variation in readings between sensors.

Dual mSensor and Blocks with 2 Terminals

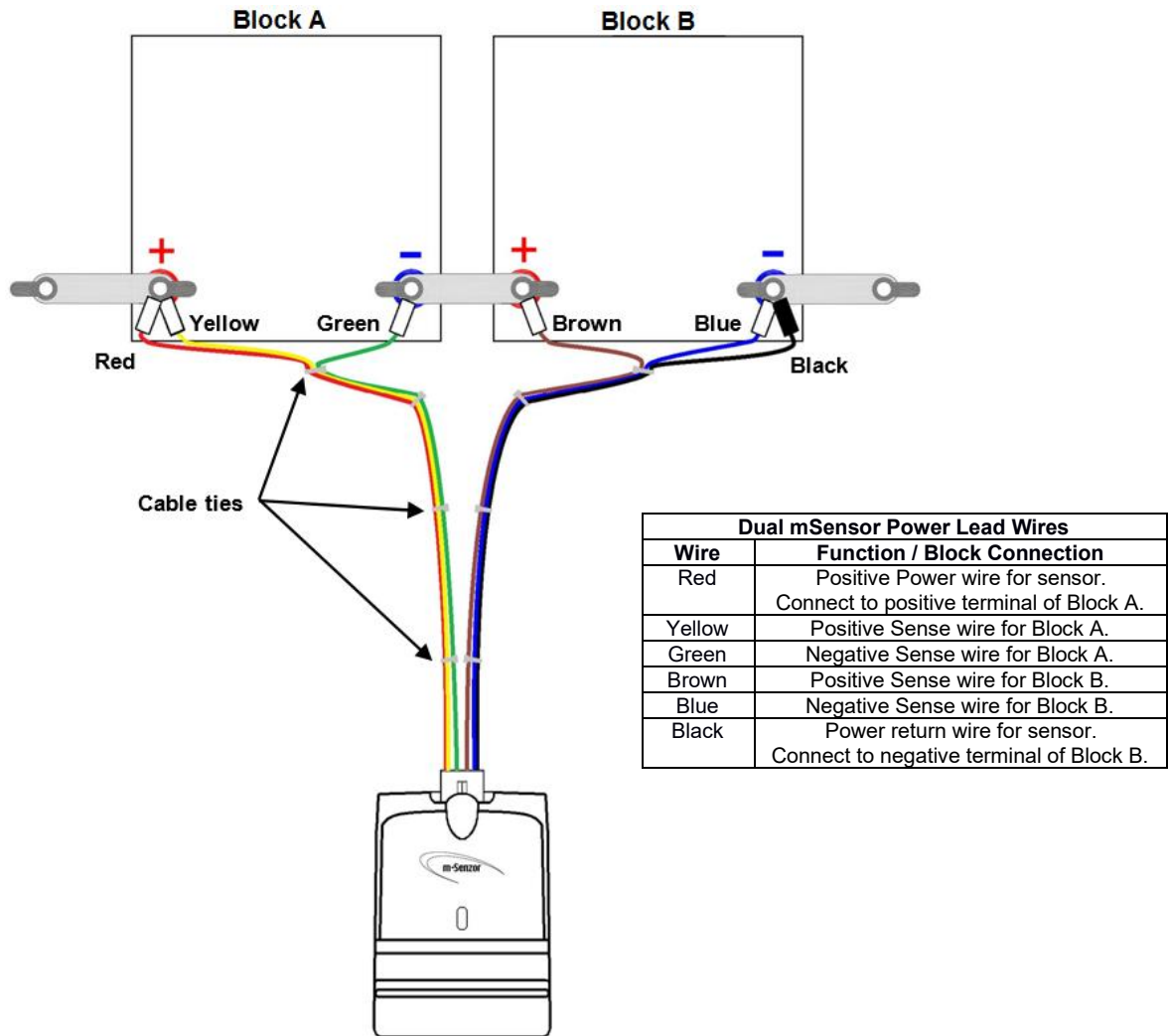

Please note the following important points:

- The power lead is manufactured with cable ties in order to keep the *Sense* wire pairs and the *Power* wires closely coupled.
- Try to keep the *Sense* wire pairs and *Power* wires closely coupled as much as possible.
- Where possible, do not remove the cable ties.
- The cable ties nearest the block terminals may need to be repositioned to allow the wires to be connected to the block terminals.
- Do not connect the Green and Brown Sense wires to the terminal of one block. Connect them to the positive and negative terminals of the respective blocks.

Single mSensor and Block with 2 Terminals

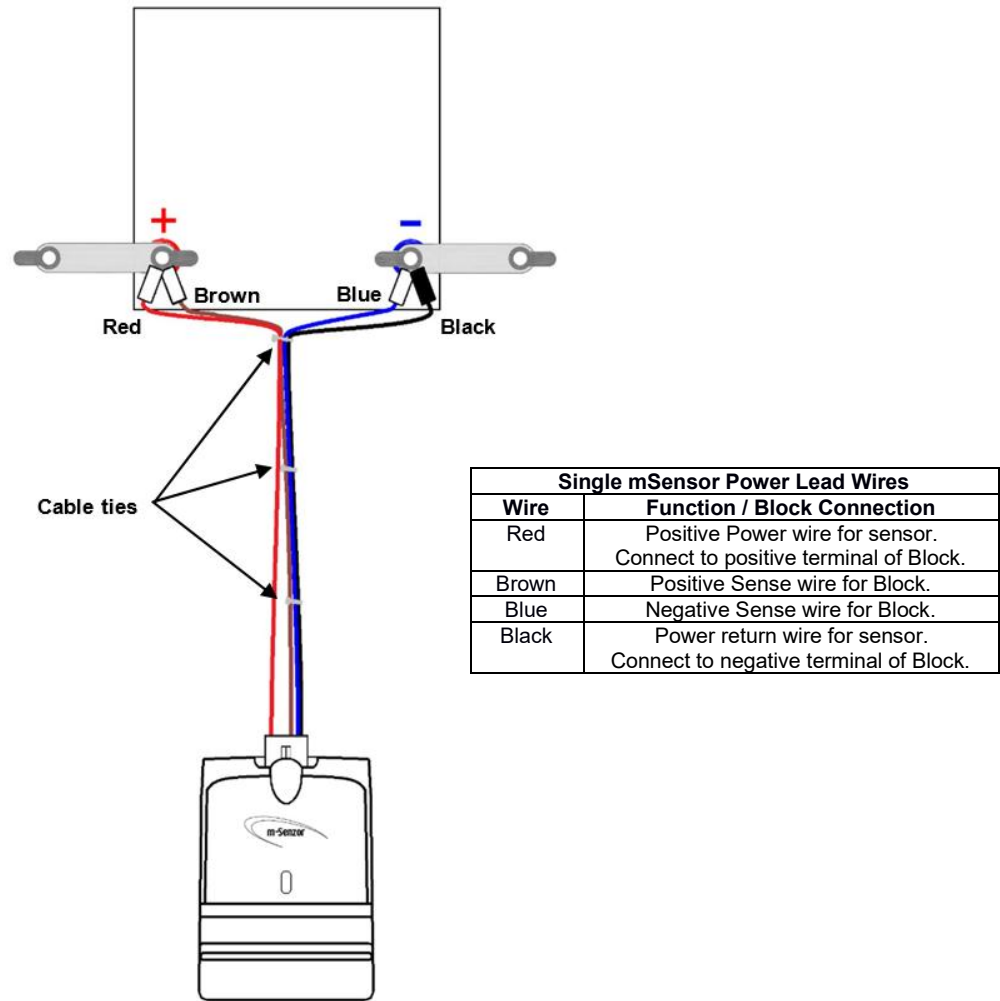

Please note the following important points:

- The power lead is manufactured with cable ties in order to keep the *Sense* wire pairs and the *Power* wires closely coupled.
- Try to keep the *Sense* wire pairs and *Power* wires closely coupled as much as possible.
- Where possible, do not remove the cable ties.
- The cable ties nearest the block terminals may need to be repositioned to allow the wires to be connected to the block terminals.

Dual mSensor and Blocks with 4 Terminals

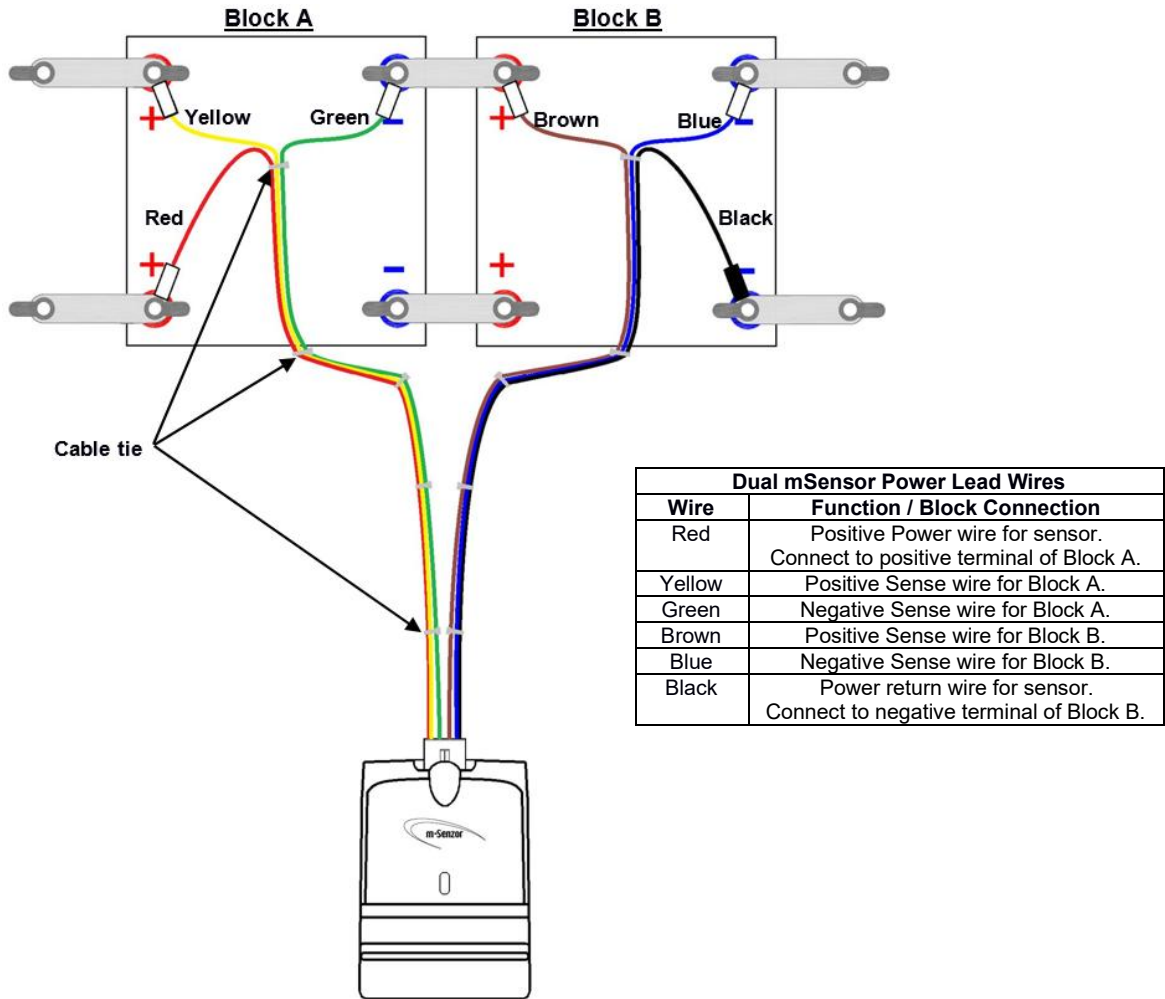

Please note the following important points:

- The power lead is manufactured with cable ties in order to keep the *Sense* wire pairs and the *Power* wires closely coupled.
- Try to keep the *Sense* wire pairs and *Power* wires closely coupled as much as possible.
- Where possible, do not remove the cable ties.
- The cable ties nearest the block terminals may need to be repositioned to allow the wires to be connected to the block terminals.
- Do not connect the Red and Black *Power* wires to the same terminals as the Yellow and Blue *Sense* wires.
- Do not connect the Green and Brown *Sense* wires to the terminal of one block. Connect them to the positive and negative terminals of the respective blocks.

Single mSensor and Block with 4 Terminals

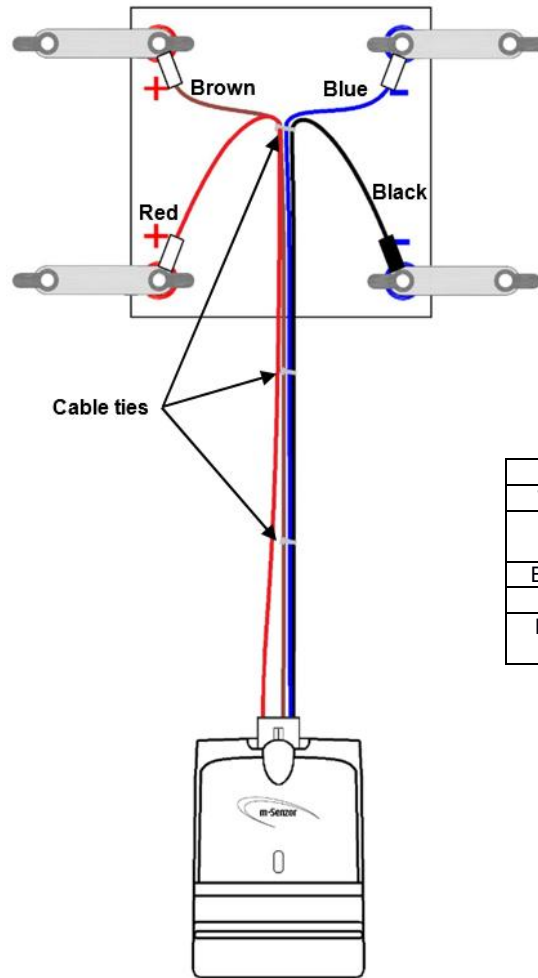

Single mSensor Power Lead Wires	
Wire	Function / Block Connection
Red	Positive Power wire for sensor. Connect to positive terminal of Block.
Brown	Positive Sense wire for Block.
Blue	Negative Sense wire for Block.
Black	Power return wire for sensor. Connect to negative terminal of Block.

Please note the following important points:

- The power lead is manufactured with cable ties in order to keep the *Sense* wire pairs and the *Power* wires closely coupled.
- Try to keep the *Sense* wire pairs and *Power* wires closely coupled as much as possible.
- Where possible, do not remove the cable ties.
- The cable ties nearest the block terminals may need to be repositioned to allow the wires to be connected to the block terminals.
- Do not connect the Red and Black *Power* wires to the same terminals as the Brown and Blue *Sense* wires.

mSensor Power Leads with Block Temperature

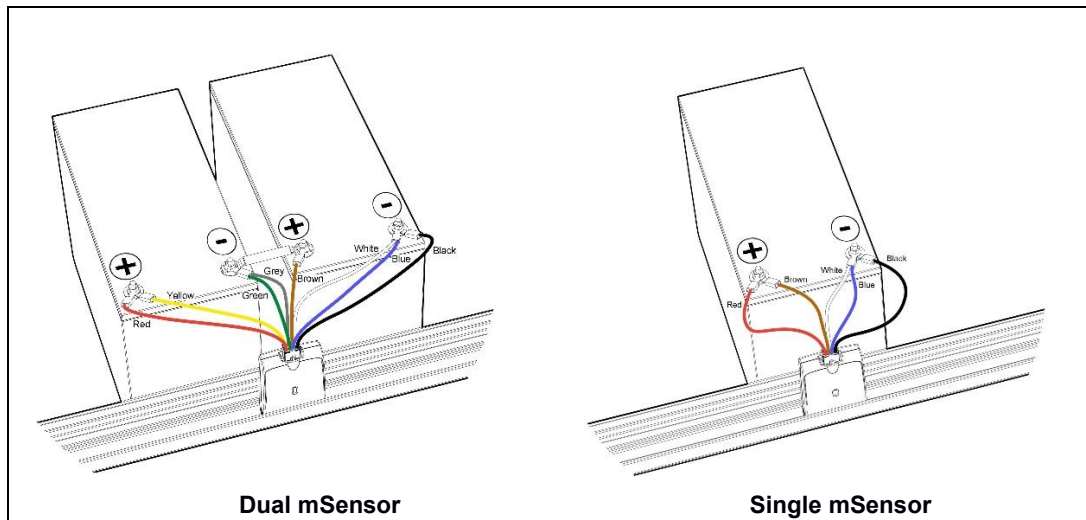

mSensor Power Leads without Block Temperature

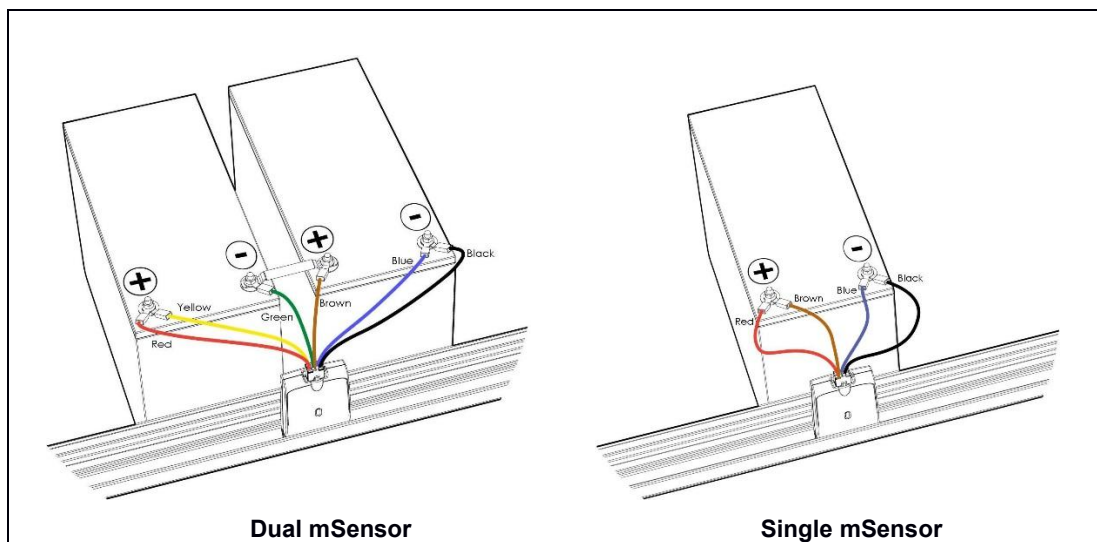

Appendix 7 – 4-Wire / Kelvin Connection

This article explains the 4-wire or Kelvin connection measurement technique in general terms. It is not intended as an in-depth guide to making high accuracy measurements of battery impedance.

Resistance

Resistance is commonly measured by passing a known test current through the resistance under test and measuring the corresponding voltage. The value of resistance is then determined from Ohms law:

$$R = V/I$$

where:

R = resistance

V= measured voltage

I = known test current

2-Wire Resistance Measurement

Simple meters measure resistance using 2 leads or probes. Internally, the meter generates a test current that is driven through the resistance under test while simultaneously measuring the voltage at the terminals of the meter. The diagram below illustrates this principle.

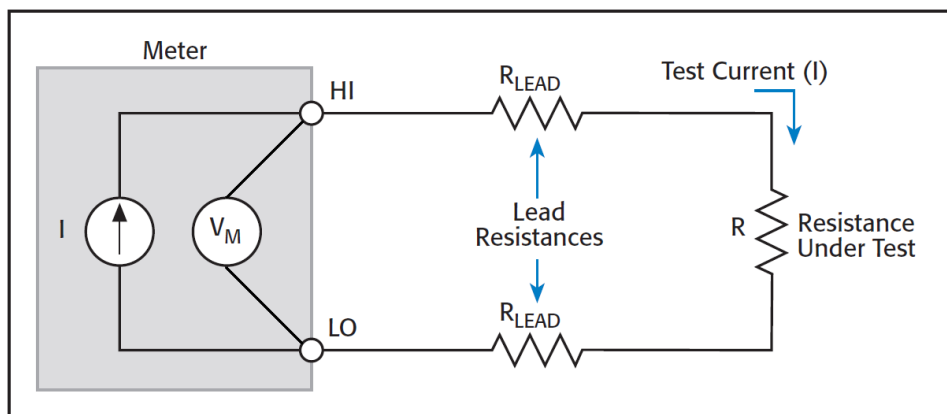

Note that the meter leads have resistance (denoted R_{LEAD} above). The points of contact of the meter probes with the resistance under test also have resistance (denoted $R_{CONTACT}$, not shown above).

As the meter measures the voltage at its terminals, the voltage developed is due to the total of all resistances in the external circuit, i.e. R , R_{LEAD} & $R_{CONTACT}$. If the lead and contact resistances are significant in value compared to the resistance under test, the lead and contact resistances result in the meter reporting a higher value for the resistance under test than its true value.

Example:

Typical meter probes can have resistances in the range $10\text{m}\Omega$ to $50\text{m}\Omega$ (a 1m length of 20AWG copper wire has a resistance of approx. $33\text{m}\Omega$). Contact resistance is usually comparable. If the total lead and contact resistance is $20\text{m}\Omega$ and the true value of the resistance under test is also $20\text{m}\Omega$, the meter will report the resistance to be $40\text{m}\Omega$. Thus, the resistance measurement error is $20\text{m}\Omega$ or 100% ($20\text{m}\Omega / 20\text{m}\Omega$).

NOTES:

- Some meters try to compensate for the lead and contact resistances using a *Null* or *Calibration* function. These functions require making a resistance measurement with either the tips of the probes shorted together or placed across a known, calibrated resistance or shunt. The measured value is then subtracted from subsequent measurements.
- Meters using the 2-wire method are generally only capable of measuring resistance to just under 1Ω with accuracy of about 50 to $100\text{m}\Omega$ as they do not have adequate accuracy or resolution.

4-Wire/Kelvin Resistance Measurement

To reduce the effect of lead and contact resistances, the 4-wire or Kelvin connection method can be used. This method requires 4 wires and thus 4 terminals at the meter as shown below. With this configuration, the test current is driven through the resistance under test using one set of leads called the Source leads. The voltage developed across the resistance under test is measured by another set of leads called the Sense leads. The Sense leads should be connected as close as possible to the resistance under test for highest accuracy.

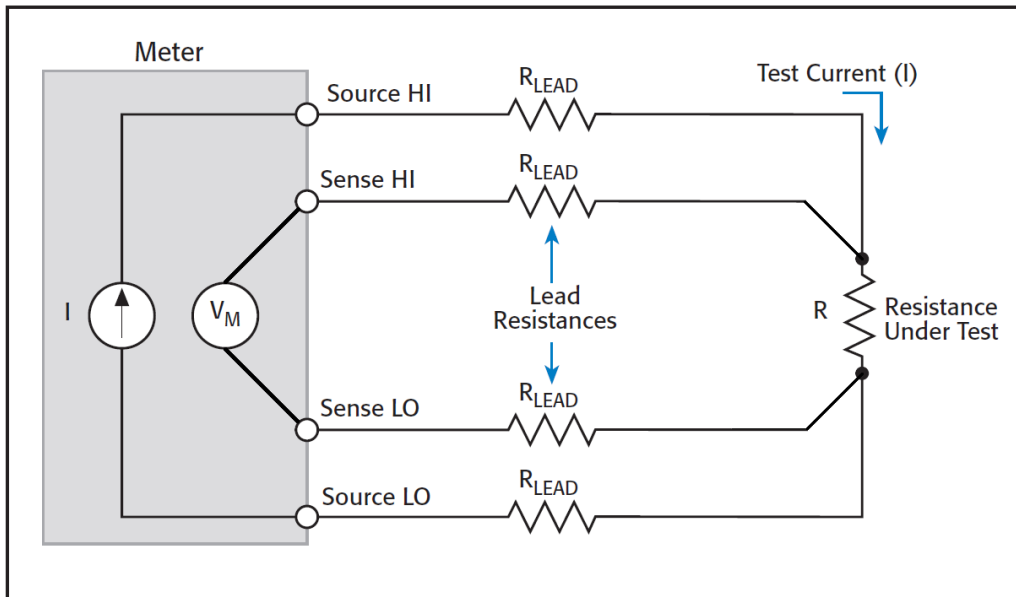

With this method, the test current does not flow in the Sense leads so there is no voltage developed across their resistance. In addition, as the Sense leads are connected directly at the resistance under test, the voltage developed by the test current flowing through the resistance of the Source leads is not measured. Thus, the meter only measures the voltage due to the test current flowing through the resistance under test which results in a more accurate reading that is not influenced by the meter leads.

NOTES:

- A very small, negligible, current does flow in the Sense leads due to the input circuitry of the meter. As long as this current is much smaller than the test current, it does not significantly affect the resistance measurement and can be ignored.
- The method of physically connecting the leads at the resistance under test can affect the measurement. If there is any appreciable contact resistance at the resistance under test due to the physical position of the leads, this contact resistance can be measured by the meter and offset the true resistance measurement.

The internal resistance of batteries used with large UPS can range from less than $1\text{m}\Omega$ for 2V batteries up to $20\text{m}\Omega$ for 12V batteries so we can see that a 2-wire approach can result in a large measurement error if lead and contact resistance are not considered.

The 4-wire or Kelvin connection method is recognised as the most accurate way to measure resistance when high accuracy and/or low sample resistances are involved.

Appendix 8 – DC Model Controller Wiring

The DC model *PowerShield Controllers* are fitted with a male 3-way input socket and are supplied with a mating female screw terminal plug. The following points must be considered:

- The Controller must be installed by a service person and connected to a socket outlet or fixed wiring with a protective earth conductor or connector.
- A readily available disconnect device shall be incorporated in the building wiring or the socket outlet near the *PowerShield Controller* that is readily accessible.
- The power source for the *PowerShield Controller* must be fused with a circuit breaker of no greater than 20A rating. The connection must be installed in a service access area.

DC Model Plug

The plug required to connect to a DC model *PowerShield Controller* is a Wieland GST15i3 3-pole female screw terminal plug (Wieland part number 91.931.3053.1) as shown below. This plug is supplied with the *PowerShield Controller*.

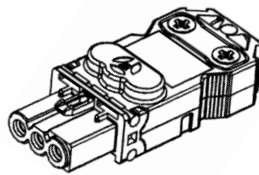

The plug specifications are shown below. It must be wired with cable of appropriate gauge and rating. We recommend using cable with minimum ratings of 5A 250V.

Parameter	Specification
Rated Voltage	250V
Rated Current	16A
Cable outer diameter	5.5mm to 9.0mm
Wire cross sectional area	0.5mm ² to 1.5mm ²

The plug is fitted with a latch to secure it to the input socket of the *PowerShield Controller*. To remove the plug, press down on the latch with a screwdriver or suitable tool and pull the plug out.

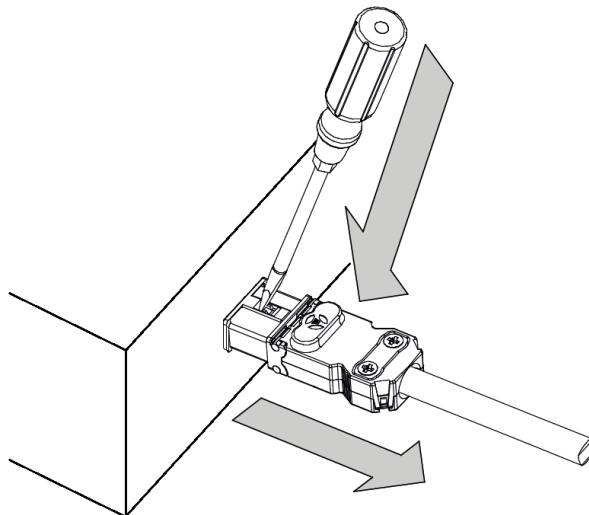

To wire and assemble the plug, please complete the following steps:

1. Remove the outer cable sheath and strip the ends of each wire as per below (lengths are in mm):

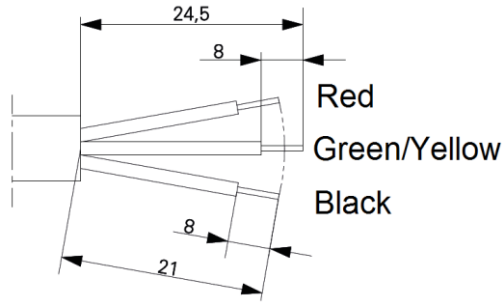

2. Insert the wires into the plug and tighten the contact screws.
The wiring should be as follows:

Plug Terminal	Wire / Function
Live	Red / DC supply positive
Earth	Earth
Neutral	Black / DC supply negative

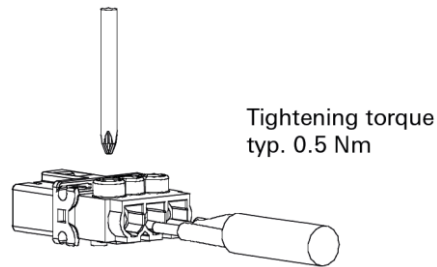

3. Fit the covers.

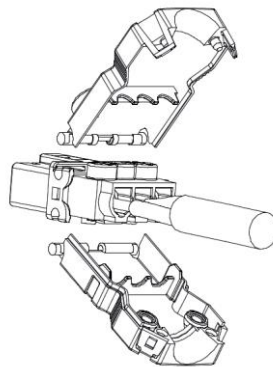

4. Tighten the strain relief screws.

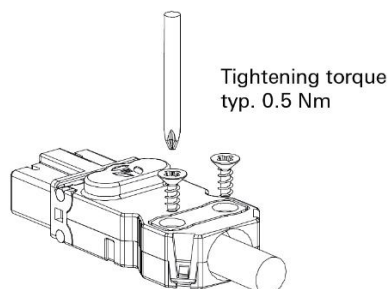

Appendix 9 – Controller Specifications

LX Controller

Configuration Interface	Web browser
Communication	
Front	1000Base-T Ethernet (Service Port) USB (Flash drive only) LCD
Rear	1000Base-T Ethernet (<i>PowerShield Link</i> software, Modbus TCP, SNMP) RS485 (optional) Wi-Fi (optional)
Hub Ports	8
Capacity	1 <i>PowerShield Hub</i> and up to 32 <i>PowerShield mSensors</i> per port
Connection	RJ45 / CAT5 cable
Maximum Distance	50m / 165ft (between <i>Controller</i> and <i>Hub</i>)
Memory	2GB RAM Up to 16GB Flash
Relays	4
Type	Single Pole Double Throw (SPDT)
Rating	1A @ 30VDC, resistive
Auxiliary Inputs	2
Type	Voltage Free / Dry Contact
Physical Dimensions	1U High 19" rack mount enclosure, mild steel with powder coat finish Width: 430mm / 16.9 inches Depth: 265mm / 10.4 inches Height: 45mm / 1.8 inches Weight: 3kg / 6.6lbs <i>The Controller must be installed in a location that allows 30mm space at the top and sides of the unit for adequate air circulation. Installation must allow unrestricted airflow.</i>
Power Supply	AC Model: 90V to 260Vac, 50/60Hz, 0.42A max. 24V DC Model: 18V to 30Vdc, 1.1A max. 48V DC Model: 35V to 60Vdc, 0.52A max. 110V DC Model: 80V to 150Vdc, 0.22A max.
Power Consumption	Typical 5W + 1.2W per Hub Max. 6W + 1.8W per Hub
Environment	Indoor use only, Overvoltage Category II, Pollution Degree 2 Operating Temperature: 0°C to 50°C / 32F to 122F Storage Temperature: 0°C to 70°C / 32F to 158F Relative Humidity: 10 to 90% non-condensing. Altitude: 2000m max.

Specifications subject to change.

MX Controller

Configuration Interface	Web browser
Communication	
Front	USB (Service Port) SD Card
Rear	1000Base-T Ethernet (<i>PowerShield Link</i> software, Modbus TCP, SNMP) RS485 (optional) Wi-Fi (optional)
Hub Ports	4
Capacity	1 <i>PowerShield Hub</i> and up to 32 <i>PowerShield mSensors</i> per port
Connection	RJ45 / CAT5 cable
Maximum Distance	50m / 165ft (between <i>Controller</i> and <i>Hub</i>)
Memory	1GB RAM 8GB Flash
Relays	1
Type	Single Pole Double Throw (SPDT)
Rating	1A @ 30VDC, resistive
Ambient Temperature	1
Type	Thermistor
Physical Dimensions	Width: 250mm / 9.84 inches Depth: 155mm / 6.10 inches Height: 36mm / 1.4 inches Weight: 1.2kg / 2.7lbs <i>The Controller must be installed in a location that allows 30mm space at the top and sides of the unit for adequate air circulation. Installation must allow unrestricted airflow.</i>
Power Supply	AC Model: 90V to 260Vac, 50/60Hz, 0.17A max. 48V DC Model: 18V to 60Vdc, 0.4A max (F1, T1A/300Vdc fuse). 110V DC Model: 80V to 150Vdc, 0.1A max (F1, T0.5A/500Vdc fuse). Note: Fuses are not replaceable.
Power Consumption	Typical 1.5W + 1.2W per Hub
Environment	Indoor use only, Overvoltage Category II, Pollution Degree 2 Operating Temperature: -100°C to 50°C / 14F to 122F Storage Temperature: 0°C to 70°C / 32F to 158F Relative Humidity: 10 to 90% non-condensing. Altitude: 2000m max.

Specifications subject to change.

Appendix 10 – Hub Specifications

Block Inputs	up to 64 (via dual <i>PowerShield mSensors</i>)
Type	<i>PowerShield mSensor</i>
Current Inputs	up to 2 (provides string DC & AC current)
Type	Hall Effect
Range	0A to ±2000A (depends on Current Transducer model used)
Maximum Distance	10m / 32ft
Temperature Inputs	2
Type	Thermistor
Range	-10°C to 80°C / 14F to 176F
Maximum Distance	15m / 50ft
Relays	1
Type	Single Pole Double Throw (SPDT)
Rating	1A @ 30VDC, resistive
Auxiliary Inputs	1
Type	Voltage Free / Dry Contact
Humidity	1
Type	On-board sensor
Range	0% to 100% Relative Humidity
Communication Interface	
Connection	RJ45 / CAT5 cable
Type	Proprietary differential bus
Protocol	Modbus
Maximum Distance	25m / 82ft (total length of wiring from <i>Hub</i> to last <i>mSensor</i>)
Physical Dimensions	Width: 120mm / 4.7 inches Depth: 107mm / 4.2 inches Height: 25mm / 1.0 inch Weight: 180g / 0.4lbs
Power Supply	24V DC via <i>PowerShield Controller</i> hub port
Environment	Indoor use only, Overvoltage Category II, Pollution Degree 2 Operating Temperature: -10°C to 50°C / 14F to 122F Storage Temperature: -10°C to 80°C / 14F to 176F Altitude: 2000m max.

Specifications subject to change

Appendix 11 – mSensor Specifications

Block Inputs	1 or 2 (depends if using a single or dual <i>mSensor</i>)			
Block Type	1.2V NiCad, 2V, 4V, 6V, 8V, 12V, 16V Lead Acid			
Nominal Voltage¹	NiCad	2V	6V	12V
Voltage Range	0.8 – 1.9V	1.6 – 2.6V	4.8 – 7.8V	9.6 – 15.6V
Voltage Resolution	1mV dc, 1mV ac	1mV dc, 1mV ac	5mV dc, 1mV ac	5mV dc, 1mV ac
Voltage Accuracy	±0.3%	±0.3%	±0.2%	±0.2%
Ohmic Range ²	0.1 – 5mΩ	0.1 – 5mΩ	0.5 – 20mΩ	1.0 – 40mΩ
Ohmic Resolution	1uΩ	1uΩ	1uΩ	1uΩ
Ohmic Accuracy	±2.5% + ±15uΩ	±2.5% + ±15uΩ	±2.5% + ±25uΩ	±2.5% + ±25uΩ
Maximum Input	±5V	±6V	±25V	±65V
Temperature Inputs	1 per Block			
Type	Thermistor, located on Negative Terminal of Block			
Range	-10°C to 80°C / 14F to 176F			
Accuracy ³ / Resolution	±1°C, 0.1°C			
Communication Interface	4P4C Modular Jack / 4-core flat modular cable			
Connection	Proprietary differential bus			
Type	Modbus			
Protocol	25m / 82ft (total length of wiring from <i>Hub</i> to last <i>mSensor</i>)			
Maximum Distance	UL certified to 600V DC (internal optical isolation)			
Isolation	Width: 106mm / 4.2 inches			
Physical Dimensions	Depth: 76mm / 3.0 inches			
	Height: 26mm / 1.0 inch			
	Weight: 110g / 0.24lbs			
Power Supply	NiCad	2V	6V	12V
Nominal Supply Current ⁴	50mA	30mA	20mA	20mA
Environment	Indoor use only, Overvoltage Category 0, Pollution Degree 2			
	Operating Temperature: 0°C to 50°C / 32F to 122F			
	Storage Temperature: -10°C to 70°C / 14F to 158F			
	Altitude: 2000m max.			

Specifications subject to change.

1. Most common models. Other models available on request.
2. NiCad single *mSensor* cannot perform ohmic measurement.
3. Over the range 0°C - 50°C.
4. From block(s) being monitored.

Appendix 12 - PowerShield8 Installation Forms

6300-107 Facility Information Form (FIF)

Facility Information

Company/Customer:	
Facility Name:	
Facility Address:	
Total Number Strings:	
Total Number PowerShield8 Systems:	
Installed by:	
Date:	

Notes

6300-108 PowerShield8 Controller Information Form (CIF)

PRINT OUT AS MANY COPIES OF THIS FORM AS REQUIRED

Facility Name:

Controller Details

System Name:	
Strings:	No. Monitored: Details (No. Blocks/Voltage):
Port 1:	Connected (Yes / No): Configuration (DHCP / Manual): Manual Config.: <ul style="list-style-type: none"> • Address: • Subnet Mask: • Gateway:
Port 2:	Installed (Yes / No): Interface Type (RS485, RS232): Baud Rate:
Port 3:	Installed (Yes / No): Interface Type (RS485, RS232): Baud Rate:
Relays:	#1 Function: #2 Function: #3 Function: #4 Function:
Auxiliary Inputs:	#1 Function: #2 Function:

Notes

6300-109 PowerShield8 String Information Form (SIF)

PRINT OUT AS MANY COPIES OF THIS FORM AS REQUIRED

Facility Name:

PowerShield8 System Name:

String # / Name:									
No. mSensors (Singles / Duals):									
Block Details				Hub Details					
Block Start #	Block End #	Block Voltage	Block Ah Rating	Hub ID	Controller Port #	CT Model	CT Direction	Temp. Sensors	Temp. Sensor Location

String # / Name:									
No. mSensors (Singles / Duals):									
Block Details				Hub Details					
Block Start #	Block End #	Block Voltage	Block Ah Rating	Hub ID	Controller Port #	CT Model	CT Direction	Temp. Sensors	Temp. Sensor Location

String # / Name:									
No. mSensors (Singles / Duals):									
Block Details				Hub Details					
Block Start #	Block End #	Block Voltage	Block Ah Rating	Hub ID	Controller Port #	CT Model	CT Direction	Temp. Sensors	Temp. Sensor Location

String # / Name:									
No. mSensors (Singles / Duals):									
Block Details				Hub Details					
Block Start #	Block End #	Block Voltage	Block Ah Rating	Hub ID	Controller Port #	CT Model	CT Direction	Temp. Sensors	Temp. Sensor Location

Example

String # / Name:				1 / UPS A1					
No. mSensors (Singles / Duals):				0 / 20					
Block Details				Hub Details					
Block Start #	Block End #	Block Voltage	Block Ah Rating	Hub ID	Controller Port #	CT Model	CT Direction	Temp. Sensors	Temp. Sensor Location
1	40	12V	150Ah	221	1	L34S800D15	Standard	2	1 = Top 2 = Bottom

